



Installation Guide



Vertical Communications, Inc. reserves the right to revise this publication and to make changes in content without notice.

© 2010 by Vertical Communications, Inc. All rights reserved.

This publication contains proprietary and confidential information of Vertical Communications, Inc. The contents of this document may not be disclosed, copied or translated by third parties, in any form, or by any means known, or not now known or conceived, without prior explicit written permission from Vertical Communications, Inc.

LIMIT OF LIABILITY/DISCLAIMER OF WARRANTY

Vertical Communications, Inc. makes no representation or warranties with respect to the accuracy or completeness of the content of this publication and specifically disclaims any implied warranty of merchantability or fitness for any particular purpose, and shall not be liable for any loss of profit or any other commercial damage, including but not limited to, special, incidental, or consequential.

TRADEMARKS

Vertical Communications and the Vertical Communications logo and combinations thereof are trademarks of Vertical Communications, Inc. All other brand and product names are used for identification only and are the property of their respective holders.

RESTRICTED RIGHTS LEGEND

Use, duplication, or disclosure of the technical data contained in this document by the Government is subject to restrictions as set forth in subdivision (c) (1) (ii) of the Rights in Technical Data and Computer Software clause at DFARS 52.227-7013 and/or in similar or successor clauses in the FAR, or in the DOD or NASA FAR Supplement. Unpublished rights reserved under the Copyright Laws of the United States. Contractor/manufacturer is Vertical Communications, Inc., 10 Canal Park, Suite 602, Cambridge, MA 02141-2249.

REVISION HISTORY

| Release | Date | Documentation Changes | Page No. |
|---------|-------|---|-----------------------------|
| 3.5 | 06-10 | Update -- EKSU (p/n 4002-03) now shows 16-port capability. | 2-4 and 4-9 |
| | | Update -- dial pad graphic has been modified. | 6-14 |
| 3.0 | 11-09 | Release 3.0 added the following new hardware: | -- |
| | | MBU (p/n 4000-03) to accommodate 3.0 boards. | 4-2 |
| | | EMBU (p/n 4002-03) to accommodate 3x16 Expansion board | 4-8 |
| | | 3x16 Expansion board (p/n 4032-16) | 4-14 |
| | | T1/PRI board (p/n 4035-00) | 4-16 |
| | | Updated the Voicemail specifications with recording times. | 4-21 |
| | | A section has been added that addresses "Loading a 2.5 database onto a 3.0 system". | 7-8 |
| | | Added a System Upgrade Configuration procedure. | 7-10 |
| 2.1 | 09-08 | Added a T1/PRI Firmware Upgrade procedure. | 8-16 |
| | | Formatting & editing have been done to certain sections for greater ease of understanding. No features have been added or removed. | -- |
| 2.0 | 07-08 | 25-pair cable pin outs have been added (p/n 4099-00). | 4-7 |
| | | A VoIB software upgrade procedure (web-based) has been added. | 8-13 |
| | | Added information on KSU administration via RJ-45 LAN port by direct connection and by connection to the KSU over a LAN switch. | 9-17 |
| | | A "BLF Manager" section has been added. | 6-16 |
| | | A section has been added that addresses uploading new VMIB prompts. | 8-9 |
| | | A system setup quick reference Appendix has been added. | Appendix A |
| | | A section has been added that addresses IP Phones on the SBX IP. | 5-22 |
| 1.0 | 01-08 | Initial Release NOTE: this document contains information on ISDN, DCOB, and SMS. These features are currently not supported. Information pertaining to DID pertains only to SIP Trunking. | -- |

Contents

| | | |
|------------------|--|-----|
| Chapter 1 | Introduction | |
| | Important Safety Instructions - - - - - | 1-1 |
| | Safety Requirements - - - - - | 1-1 |
| | Precautions - - - - - | 1-2 |
| | Cautions - - - - - | 1-2 |
| | Disposal of Old Units - - - - - | 1-3 |
| | Using this Manual - - - - - | 1-4 |
| Chapter 2 | System Overview | |
| | SBX IP System Highlights - - - - - | 2-1 |
| | Supported phones - - - - - | 2-1 |
| | System Connection Diagram - - - - - | 2-2 |
| | System Components - - - - - | 2-3 |
| | Basic KSU (p/n 4000-00) - - - - - | 2-3 |
| | Expansion KSU (p/n 4002-00) - - - - - | 2-3 |
| | KSU (p/n 4000-03) for 3.0 s/w or higher - - - - - | 2-4 |
| | EKSU (p/n 4002-03) for 3.0 s/w or higher - - - - - | 2-4 |
| | System Specification Tables - - - - - | 2-5 |
| | Board Capacities - - - - - | 2-5 |
| | System Capacities - - - - - | 2-6 |
| | Dialing Specifications - - - - - | 2-7 |
| | Dimensions and Weight - - - - - | 2-7 |
| | Environmental Specifications - - - - - | 2-7 |
| | Electrical Specifications - - - - - | 2-8 |
| Chapter 3 | KSU Installation | |
| | Pre-Installation - - - - - | 3-1 |
| | Safety Installation Instructions - - - - - | 3-1 |
| | Installation Precautions - - - - - | 3-2 |

Wiring Precautions ----- 3-2

KSU Installation ----- 3-3

 Unpacking ----- 3-3

 KSU Exterior and Dimension ----- 3-4

 Opening and Closing the Front Cover ----- 3-5

 Frame Ground Connection ----- 3-7

 External Backup Battery Installation ----- 3-8

 KSU Mounting ----- 3-9

Expansion KSU Installation ----- 3-12

 Unpacking ----- 3-12

 Connecting the Expansion KSU to the Basic KSU ----- 3-13

 Expansion KSU Mounting ----- 3-15

Chapter 4 Board Installation

Basic Board Installations ----- 4-2

 Main Board Unit (p/n: 4000-00) ----- 4-2

 Main Board Unit (p/n: 4000-03) ----- 4-2

 Modular Jack (MJ1 - MJ3) Pin Assignment ----- 4-4

 Switch, LED, and Connector ----- 4-6

 SBX 25-Pair Installation Cable Pinouts ----- 4-7

Expansion Main Board Unit (EMBU) ----- 4-8

 Expansion MBU (p/n: 4002-00) ----- 4-8

 Expansion MBU (p/n: 4002-03) ----- 4-8

 Modular Jack (MJ1 - MJ3) Pin Assignment ----- 4-10

CO Line and Extension Boards ----- 4-12

 3x8 Expansion Board (3 CO Line and 8 Hybrid) ----- 4-12

 3x16 Expansion Board (3 CO Line and 16 Digital) ----- 4-13

Other Board Installations (optional) ----- 4-14

 Digital Telephone Interface Board (DTIB16) ----- 4-14

 Modem Function Unit (MODU) ----- 4-15

 T1/PRI Interface Board ----- 4-16

 VoIP -- Voice Over Internet Protocol Board (4ch) ----- 4-18

 Voice Mail Interface Board (VMIB) ----- 4-21

| | | |
|------------------|---|------|
| Chapter 5 | Terminal Connection and Wiring Method | |
| | Terminal and Doorbox Models ----- | 5-1 |
| | Terminal Cabling Distance ----- | 5-3 |
| | Basic Terminal Connection ----- | 5-4 |
| | DKT and DSS ----- | 5-4 |
| | SLT ----- | 5-4 |
| | Doorbox ----- | 5-5 |
| | Connecting Additional Terminals ----- | 5-7 |
| | External Music Source Wiring ----- | 5-8 |
| | Relay Contacts ----- | 5-8 |
| | External Paging Port Wiring ----- | 5-8 |
| | Alarm Detection Wiring ----- | 5-8 |
| | Cable Wiring ----- | 5-9 |
| | Wall Mount Wiring ----- | 5-9 |
| | Rack Mount Wiring ----- | 5-10 |
| | IP Phones on the SBX IP ----- | 5-11 |
| | Supported IP phones: ----- | 5-11 |
| | Minimum requirements ----- | 5-11 |
| | IP endpoint licensing ----- | 5-12 |
| | IP Addressing ----- | 5-12 |
| | Preparation ----- | 5-14 |
| | PCAdmin Connection ----- | 5-14 |
| | Configuring IP phone settings ----- | 5-20 |
| | Programming VoIP card settings from a digital station --- | 5-22 |
| Chapter 6 | Starting the SBX IP System | |
| | Before Starting the SBX IP System ----- | 6-1 |
| | Basic Programming ----- | 6-2 |
| | DKT Programming ----- | 6-2 |
| | Entering the Programming Mode ----- | 6-5 |
| | Pre-Programming ----- | 6-6 |
| | BLF Manager ----- | 6-16 |
| | BLF Manager Installation ----- | 6-16 |
| | BLF Manager in detail ----- | 6-17 |

| | | |
|------------------|---|------|
| | System list window (Status of systems) - - - - - | 6-17 |
| | Station list window (Extension status) - - - - - | 6-18 |
| | Network traffic window - - - - - | 6-18 |
| | File menu - - - - - | 6-18 |
| Chapter 7 | Using Database Upload/Download | |
| | PC Requirement - - - - - | 7-1 |
| | Connection Method with SBX IP - - - - - | 7-1 |
| | Installation - - - - - | 7-2 |
| | Main software components - - - - - | 7-2 |
| | Choosing Up/Download and Connection Type - - - - - | 7-2 |
| | User Information Dialog - - - - - | 7-3 |
| | Starting Database File Upload/Download - - - - - | 7-6 |
| | Transferring Process - - - - - | 7-7 |
| | Finishing DataBase File Upload/Download - - - - - | 7-7 |
| | Loading a 2.5 Database into a 3.0 System - - - - - | 7-8 |
| | Loading the Database - - - - - | 7-8 |
| | Example -- System Upgrade Configuration - - - - - | 7-10 |
| Chapter 8 | Upgrade Process | |
| | Software Upgrade - - - - - | 8-1 |
| | Minimum PC Requirement - - - - - | 8-1 |
| | Connection Method with SBX IP - - - - - | 8-1 |
| | Installation - - - - - | 8-2 |
| | File Component in the Execution Directory - - - - - | 8-2 |
| | Choosing Up/Download and Connection Type - - - - - | 8-2 |
| | User Information Dialog - - - - - | 8-3 |
| | Starting Software Upgrade - - - - - | 8-6 |
| | Transferring Process - - - - - | 8-7 |
| | Completing Software Upload - - - - - | 8-7 |
| | Uploading new VMIB prompts - - - - - | 8-9 |
| | Prerequisites: - - - - - | 8-9 |
| | Upgrading Voice Prompts - - - - - | 8-9 |
| | VoIP Software Upgrade by Web-based Connection - - - - - | 8-13 |
| | T1/PRI Firmware Upgrade - - - - - | 8-16 |

| | | |
|------------------|---|------|
| | Verify network settings | 8-16 |
| | Downloading firmware file | 8-16 |
| Chapter 9 | Remote Diagnostics | |
| | Introduction | 9-1 |
| | Hardware/Software Minimum Requirements | 9-1 |
| | Hardware Configuration | 9-2 |
| | Installing Software | 9-2 |
| | Uninstalling Software | 9-3 |
| | Important Notes for Users | 9-3 |
| | Full Screen Layout | 9-4 |
| | File Menu | 9-4 |
| | Open Sub-menu | 9-5 |
| | Capture On Sub-menu | 9-5 |
| | Capture Off Sub-menu | 9-5 |
| | Connection Menu | 9-6 |
| | Serial Port Connection with SBX IP System | 9-6 |
| | Modem Connection with the SBX IP System | 9-9 |
| | LAN Connection with the SBX IP System | 9-17 |
| | Commands Menu | 9-28 |
| | Executing Commands | 9-29 |
| | Functions of Commands | 9-31 |
| | View Menu | 9-46 |
| | Toolbar Sub-menu | 9-46 |
| | Command Bar Sub-menu | 9-47 |
| | Input Box Bar Sub-menu | 9-47 |
| | Clear New Sub-Menu | 9-47 |
| | Help Menu | 9-48 |
| | About SBX Remote Diagnostic Tool Sub-menu | 9-48 |
| | Data Display Area | 9-49 |
| | Data Display Functions | 9-49 |
| | Automatic Data Storing Functions | 9-50 |
| | VoIB Maintenance | 9-51 |

Chapter 10 Troubleshooting

Symptoms and Solutions ----- 10-1

Appendix A System Setup Quick Reference

Quick Start ----- A-1

 To initialize the system database: ----- A-1

 To set the KSU admin password: ----- A-1

 To set the KSU LAN port IP address: ----- A-1

 Default passwords ----- A-2

 RS-232 port settings ----- A-2

 Default IP address ----- A-2

Index

Introduction

Important Safety Instructions

Safety Requirements

When using the telephone equipment, basic safety precautions should always be followed to reduce the risk of fire, electric shock, and other personal injury. Please take the following precautions:

- Read and understand all instructions.
- Follow all warnings and instructions as marked on the product.
- Unplug this product from the wall outlet before cleaning. A damp cloth should be used for cleaning. Do not use liquid or aerosol cleaners.
- Do not use this product near water: such as in a bathtub, sink, or swimming pool.
- Do not place this product on an unstable stand or table. If the product falls, serious damage can result.
- Do not place this product on a bed, sofa, or other soft surface. Doing so may prevent proper ventilation for the slots in the back or bottom of the KSU (key system unit), causing the product to overheat. Do not place this product near or over a radiator or other heat source. Do not use this product for in a built-in installation without proper ventilation.
- Use this product only with the type of power source indicated on the product label. If you are not sure of the type of power supply appropriate for the intended location, consult your dealer or local power company.
- Do not allow anything to rest on the power cord. Do not place this product in an area in which might step or trip on the cord.
- Do not overload wall outlets and extension cords. This may result in fire or electric shock.
- Never push objects of any kind into this product through the slots or connectors. This risks damage to the product, as well as fire and electric shock.
- Never pour or spill liquid of any kind on the product.
- To reduce the risk of electric shock, do not disassemble this product. Instead, take it to a qualified person when service or repair work is required. Opening or removing covers may expose you to dangerous voltages or other risk. Incorrect reassembly can cause electric shock when the appliance is subsequently used.

- Unplug this product and refer servicing to qualified service personnel if/when:
 - the power supply cord or plug is damaged or frayed.
 - liquid has been spilled onto the product.
 - the product does not operate normally by following the operating instructions.
- NOTE:** Adjust only those controls that are covered by the operating instructions. Improper adjustment of other controls may result in damage that can require extensive repair work by a qualified technician.
- the product has been dropped or the KSU has been damaged.
 - the product exhibits a distinct change in performance.
 - Avoid using a telephone during an electrical storm, as there may be a remote risk of electric shock from lightning.
 - In the event of a gas leak, do not use the telephone near the leak.

Precautions

- Keep the system away from heating appliances and electrical noise-generating devices such as fluorescent lamps, motors and televisions. These noise sources can interfere with the performance of the SBX IP system.
- This system should be kept free of dust and moisture, and should not be exposed to high temperature, vibration, or direct sunlight.
- Do not attempt to insert wires or pins into the system. If the system does not operate properly, the equipment should be repaired by an authorized service center.
- Do not use benzene, paint thinner, or an abrasive powder to clean the KSU. Clean it by wiping with a soft cloth.

Cautions

- This system should be installed and serviced by qualified service personnel only.
- When a failure occurs which exposes any internal parts, disconnect the power supply cord immediately, and return the system to the dealer.
- To protect the PCB from static electricity, discharge body static before touching connectors and/or components by touching the ground or wearing a ground strap.

Warning: There is a danger of explosion if the battery is incorrectly replaced. Replace it only with the same or equivalent type recommended by the manufacturer. Dispose of used batteries according to the manufacturer's instructions.

Disposal of Old Units

The symbol below designates a product covered by the European Directive 2002/96/EC.

- All electric and electronic products must be disposed of in special collection facilities appointed by government or local/municipal authorities.
- The correct disposal of the old appliances will help prevent potential negative consequences for the environment as well as human health.
- For more detailed information about disposal of the old appliances, please contact the waste disposal service in your area, or the place of product purchase.



Using this Manual

This document provides general information covering the hardware description and installation of the SBX IP system. While every effort has been taken to ensure the accuracy of this information, Vertical Communications, Inc. makes no warranty of accuracy or interpretations thereof.

[Chapter 2 - System Overview](#)

General information on the SBX IP system, including system specifications and capacity.

[Chapter 3 - KSU Installation](#)

Detailed instructions for planning the installation site, and procedures to install the SBX IP system.

[Chapter 4 - Board Installation](#)

Detailed instructions for installing components of the SBX IP board.

[Chapter 5 - Terminal Connection and Wiring Method](#)

Description of the kinds of terminals (including maximum distance) and other device connections for each terminal.

[Chapter 6 - Starting the SBX IP System](#)

Instructions for starting the system, and instructions for basic admin programming.

[Chapter 7 - Using Database Upload/Download](#)

Procedures for the upload/download of SBX IP MBU Database from/to a PC file

[Chapter 8 - Upgrade Process](#)

Procedures for upgrading the KSU software.

[Chapter 9 - Remote Diagnostics](#)

Procedures for diagnosing system problems and performing system maintenance from a remote site.

[Chapter 10 - Troubleshooting](#)

Information on troubleshooting common issues on the SBX IP system.

System Overview

SBX IP System Highlights

Features of the SBX IP system include:

- Flexible architecture
- Simplified system structure
- Powerful PC application via LAN, Modem, RS-232C (serial port)
- Stable and enhanced voice features
- Simple installation and efficient system management:
 - Remote admin and software upgrade through LAN connection
 - Remote admin and software upgrade through PSTN modem
- Value-added features
 - Distinctive voice mail (ADPCM 32 Kbps)
 - Basic CID (CO and SLT) function
 - 8 Poly internal MOH (13 music sources)

Supported phones

| MODEL | DESCRIPTION |
|----------|--|
| 7208D | 8-button digital telephone |
| 7224D | 24-button digital telephone |
| IP7008D | 8-button IP telephone |
| IP7024D | 24-button IP telephone |
| IP7024LD | 24-button IP telephone (large display) |
| Nomad IP | Wireless IP telephone |
| Nomad SP | Soft Phone |

System Connection Diagram

The following diagram shows the components that make up the SBX IP system:

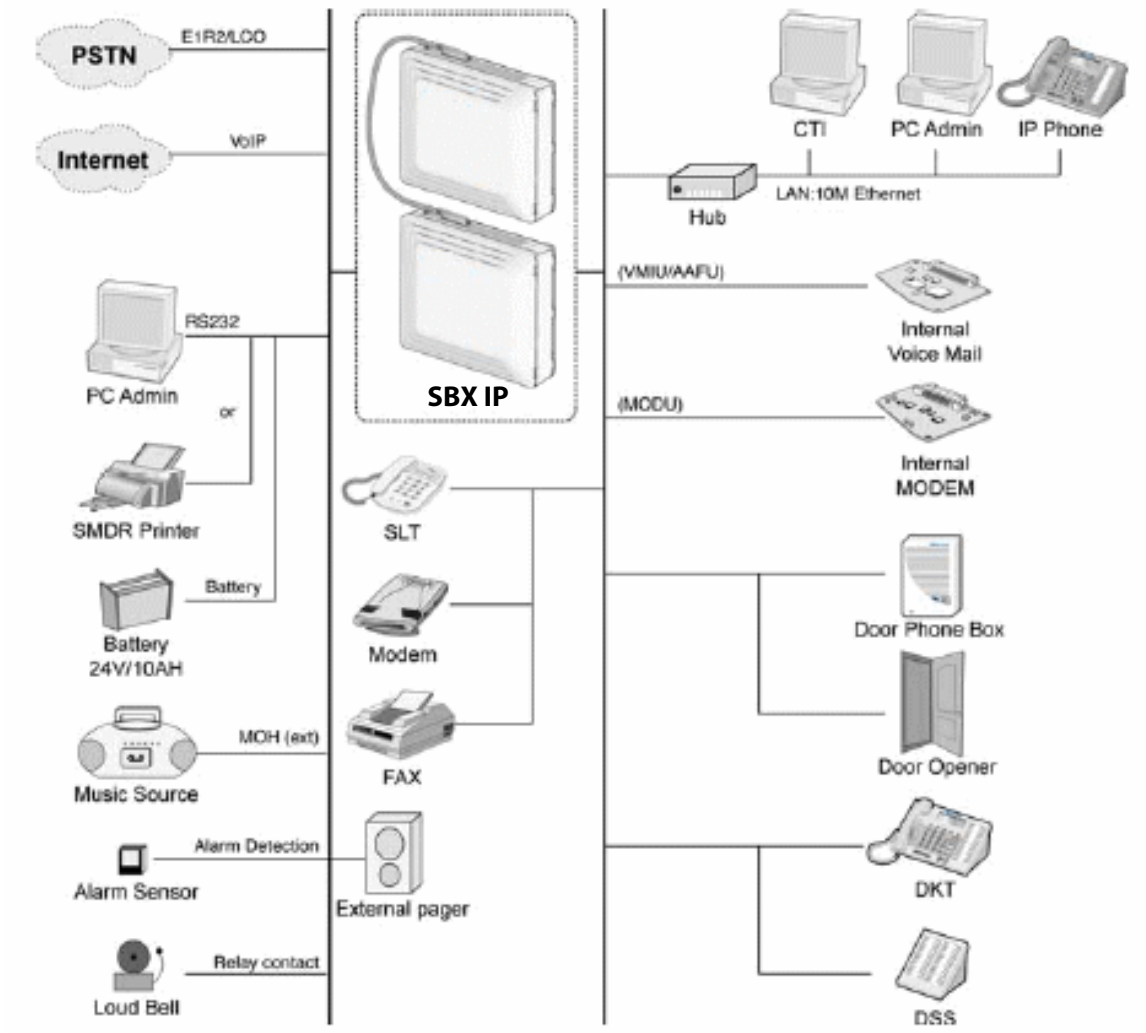

System Components

Basic KSU (p/n 4000-00)

| ITEM | DESCRIPTION |
|-------------------------|---|
| BKSU | Power Supply Unit (PSU) Main Board Unit (MBU) 3x8 Expansion Board (3 CO, 1 DKT, and 7 Hybrid) |
| <i>OPTIONAL BOARDS:</i> | |
| 3x8 Expansion Board | 3 CO, 1 DKT, and 7 Hybrid |
| MODU | Analog Modem -- Bell, ITU-T, V.34 V.32BIS, V.90 |
| VMIB | Voice Mail Interface Board, 4 channels |
| VoIB | LAN Interface Board |
| <i>NOT SUPPORTED</i> | EKSU (p/n 4002-03) T1/PRI Board DTIB16 Board |

Expansion KSU (p/n 4002-00)

| ITEM | DESCRIPTION |
|-------------------------|--|
| EKSU | Power Supply Unit (PSU) Expansion Main Board Unit (EMBU) 3x8 Expansion Board (3 CO, 1 DKT, and 7 Hybrid) |
| <i>OPTIONAL BOARDS:</i> | |
| 3x8 Expansion Board | 3 CO, 1 DKT, and 7 Hybrid |
| <i>NOT SUPPORTED</i> | KSU (p/n 4000-03) 3x16 Expansion Board |

KSU (p/n 4000-03) for 3.0 s/w or higher

| ITEM | DESCRIPTION |
|-------------------------|--|
| BKSU | Power Supply Unit (PSU) Main Board Unit (MBU) |
| <i>OPTIONAL BOARDS:</i> | |
| 3x8 Expansion Board | CO Line and DKT/SLT Interface Board |
| MODU | Analog Modem -- Bell, ITU-T, V.34 V.32BIS, V.90 |
| T1/PRI | Digital trunk interface and 8 hybrid stations |
| VMIB | Voice Mail Interface Board, 4 channels |
| VoIB | LAN Interface Board |
| <i>NOT SUPPORTED</i> | EKSU (p/n 4002-00) |

EKSU (p/n 4002-03) for 3.0 s/w or higher

| ITEM | DESCRIPTION |
|-------------------------|--|
| EKSU | Power Supply Unit (PSU) Expansion Main Board Unit (EMBU) 3x16 Expansion Board (3 CO, 16 DKT) |
| <i>OPTIONAL BOARDS:</i> | |
| 3x8 Expansion Board | 3 CO, 1 DKT, and 7 Hybrid |
| 3x16 Expansion Board | 3 CO, 16 Digital ports |
| <i>NOT SUPPORTED</i> | KSU (p/n 4000-00) |

System Specification Tables

Board Capacities

| DESCRIPTION | CAPACITY | BOARD |
|--|-------------------|---|
| Alarm Input | 1 | MBU |
| CO Line Ports | 4 (Total 12) | 3x8 Expansion |
| DTMF/CPT Receiver Channels | 16 chs | MBU |
| External MOH | 1 | MBU |
| External Paging Port | 1 | MBU |
| External Relay Contact | 4 | MBU (2), EMBU (2) |
| FSK Receiver Channels | 16 chs | MBU |
| Internal MOH (13 Music Sources) | 1 | MBU |
| LAN | 3 | MBU, VoIB, E1HB8 |
| Max Direct Station Connections (DKT/SLT/DSS) | 4 (Total 32) | 3x8 Expansion |
| MODEM Channel | 1 | MODU |
| MODU | 1 | Modem Unit |
| | Analog Modem | Bell, ITU-T, V.34 V.32BIS, V.90 |
| | Speed | 300bps up to 33Kbps speed rate |
| | Connection | Automatic rate negotiation |
| Power Fail Circuits | 3 | MBU (1), EMBU (1), 3x8 Expansion (1) |
| RS-232C Port | 1 | MBU |
| VoIB | 1 | Voice over Internet Board |
| | LAN Interface | 10 Base-T Ethernet (IEEE 802.3) |
| | Speed | 10/100 auto-negotiation, 100 Mbps recommended |
| | Duplex | Half or Full Duplex (Auto-Negotiation) |
| | VoIP Protocol | H.323 Revision 4 |
| | Voice Compression | -- G.711/G.726/G729/G.723.1 |
| | Echo Cancellation | -- G.165 |

System Capacities

| ITEM | CAPACITY | SPECIFICATION |
|-------------------------|------------------------|----------------------------------|
| Attendant Positions | 5 - Main 1 - System | -- |
| Authorization Codes | 200 | 3-11 digits each |
| CO Line Groups | 24 | -- |
| Conference | 3-15 Parties | All ports are available |
| Multi-line Conference | 3-15 Parties | Max. 3 groups |
| Hunt Groups | 10 groups | (620-629) 26 stations per group |
| Intercom Links | Non-Blocking | -- |
| Last Number Redial | 15-50 | 32 digits, via admin programming |
| Memory Back-up Duration | 10 years | -- |
| Paging Zones | | |
| - All Call | 1 | (549) |
| - External | 1 | (545) |
| - Internal | 10 | (501-510) |
| Station Groups | 10 | -- |
| Station Speed Dial | 100 | (000-099) 24 digits each |
| System Speed Dial | 500 | (2000-2499) 24 digits each |
| Time Slots | 128 | -- |

Dialing Specifications

| ITEM | DESCRIPTION | SPECIFICATION |
|-------------------------|------------------------|---------------------------------|
| DTMF Dialing | Frequency Deviation | Less than +/-1.8% |
| | Signal Rise Time | 5 ms |
| | Tone Duration, on time | Min. 50 ms, Normally 100 ms |
| | Inter-digit Time | Min. 30 ms, Normally 100 ms |
| Pulse Dialing | Pulse Rate | 10 PPS |
| | Break/Make Ratio | 60/40% or 66/33% |
| Ring Detect Sensitivity | -- | 30Vrms @ 16-55Hz |
| Ring Signal | -- | 75Vrms, 25Hz |
| Switching Device | -- | Custom Mixed-Signal ASIC Device |

Dimensions and Weight

| ITEM | HEIGHT | WIDTH (mm / in) | DEPTH | WEIGHT (kg / lbs) |
|----------------------|-------------|--------------------|------------|----------------------|
| KSU / EKSU Cabinet | 288 / 11.34 | 339 / 13.35 | 85 / 3.35 | 1.80 / 3.9 |
| IP Keypad (IP7008D) | 114 / 4.49 | 202 / 7.95 | 175 / 6.89 | 0.73 / 1.6 |
| IP Keypad (IP7024D) | 124 / 4.88 | 268 / 10.55 | 203 / 7.99 | 0.95 / 2.1 |
| IP Keypad (IP7024LD) | 147 / 5.79 | 268 / 10.55 | 243 / 9.57 | 1.03 / 2.3 |

Environmental Specifications

| ITEM | DESCRIPTION | SPECIFICATION |
|-----------------------|-------------|--------------------------|
| Operating Environment | Temperature | 0 (°C) – 40 (°C) |
| | Humidity | 0 - 80% (non-condensing) |

Electrical Specifications

| ITEM | DESCRIPTION | SPECIFICATION |
|--------------------------|----------------------|---|
| BatteryBackup (External) | Input Voltage | +24 Volt DC (+12VDC x 2ea) |
| | Battery Fuse | 5.0A @250Volt AC |
| | Charging Current | Max. 200mA |
| | Battery Load Current | Max. 3A (BKSU only), Max. 6A (BKSU + EKSU) |
| CPU | -- | ARM7 TDMI core (32bit, 50MHz) |
| External Paging Port | -- | 0dBm @ 600ohm |
| External Relay Contact | -- | 1A @ 30Volt DC |
| Music Source Input | -- | 0dBm @ 600ohm |
| Power Supply Unit (PSU) | AC Voltage Input | 100-240 +/- 10% Volt AC @47-63Hz |
| | AC Power Consumption | 90W |
| | AC Input Fuse | 2A @250Volt AC |
| | DC Output Voltage | +5, -5, +27, +30Volt DC |

KSU Installation

Pre-Installation

Please read the following guidelines concerning installation and connection before installing the SBX IP system. Be sure to comply with all applicable local regulations.

NOTE: Also, refer to the double-sided Quick Start Card included with the KSU.

Safety Installation Instructions

When installing the telephone wiring, basic safety precautions should always be followed to reduce the risk of fire, electric shock and personal injury. Please take the following precautions:

- Never install the telephone wiring during a lightning storm.
- Never install the telephone jack in wet or damp locations, unless the jack is specifically designed for wet locations.
- Never touch un-insulated telephone wires or terminals unless the telephone line has been disconnected at the network interface.
- Use caution when installing or modifying telephone lines.
- Anti-static precautions should be taken during installation.

Installation Precautions

The SBX IP system is designed for wall mounting or a free-standing rack.

DO NOT install the system in the following situations:

- In direct sunlight and in hot, cold, or humid places (acceptable temperature range = 0 to 40°C).
- In places where shocks or vibrations are frequent or strong.
- In dusty places, or places where water or oil may come into contact with the system.
- Near high-frequency generating devices such as sewing machines or electric welders.
- On or near computers, fax machines, other office equipment, microwave ovens or air conditioners.
- In any manner that obstructs the openings on the top of the SBX IP system.
- With the optional service boards stacked.

Wiring Precautions

Be sure to **follow these precautions** when wiring:

- Do not wire the telephone cable in parallel with an AC power source, such as a computer or fax machine. If the cables are run near those devices, shield the cables with metal tubing, or use shielded cables, and ground the shields.
- If the cables are run on the floor, use protectors to prevent the wires from being stepped on. Avoid running wire under carpets.
- Avoid using the same power supply outlet for computers, fax machine, and other office equipment. This reduces induction noise interruption when using the SBX IP near other machines.
- Make sure the power and battery switches are OFF during wiring. After wiring is completed, the power switch may be turned ON.
- Incorrect wiring may cause the SBX IP system to operate improperly. If an extension does not operate properly, disconnect the telephone from the extension line and then reconnect, or turn the system power OFF, and then ON again.
- Use twisted pair cable for connecting CO lines.

KSU Installation

Unpacking

Open the packaging and verify the items shown in the following figure are included:



Key Service Unit

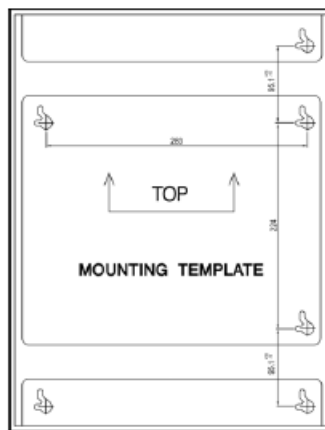

Mounting template



CD manual



Power cord



Tie cable



Battery cable



Rubber feet



Anchor plug



Screw



Fuse



Relay connector

KSU Exterior and Dimension

The following diagram shows the exterior and dimensions of the KSU:

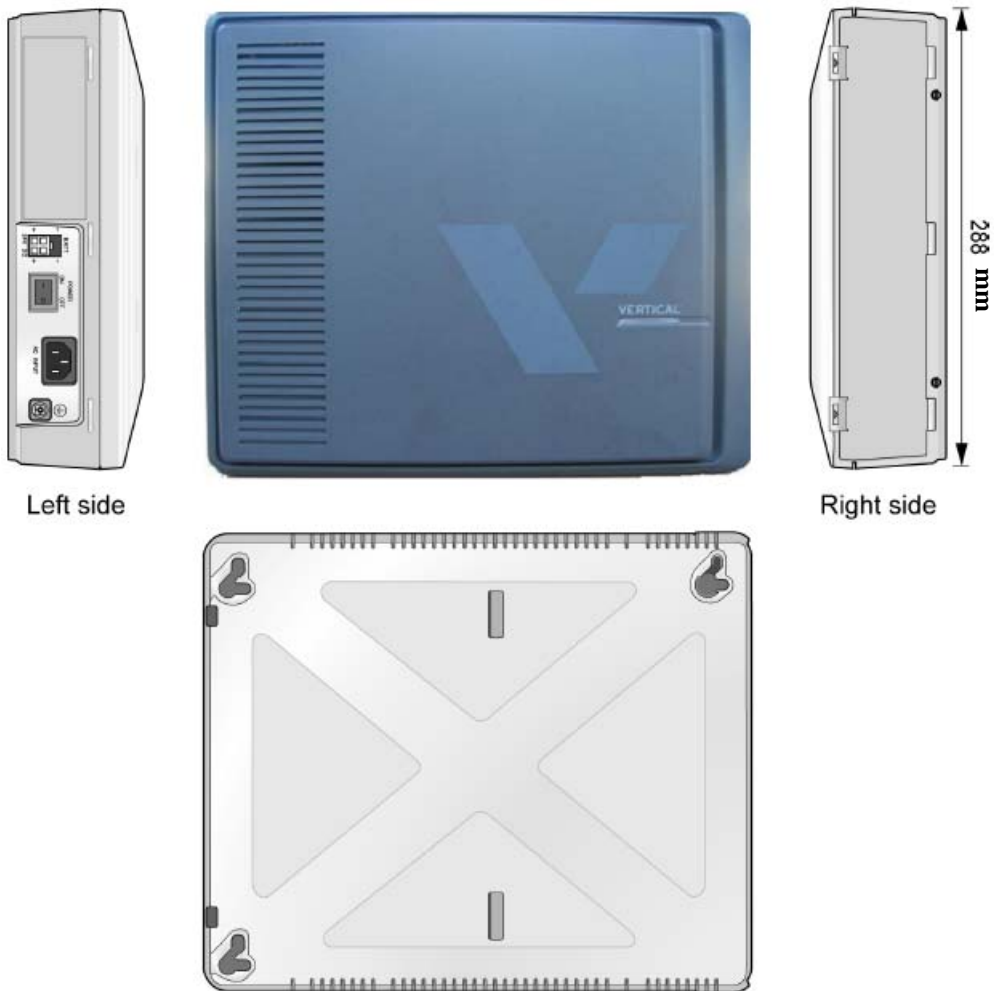

Opening and Closing the Front Cover

Opening the Front Cover

1. Open the cord cover, and turn the screws counter-clockwise to loosen (as shown in [Figure 3-1](#)).
2. Lift the front cover in the direction of the arrow as shown.

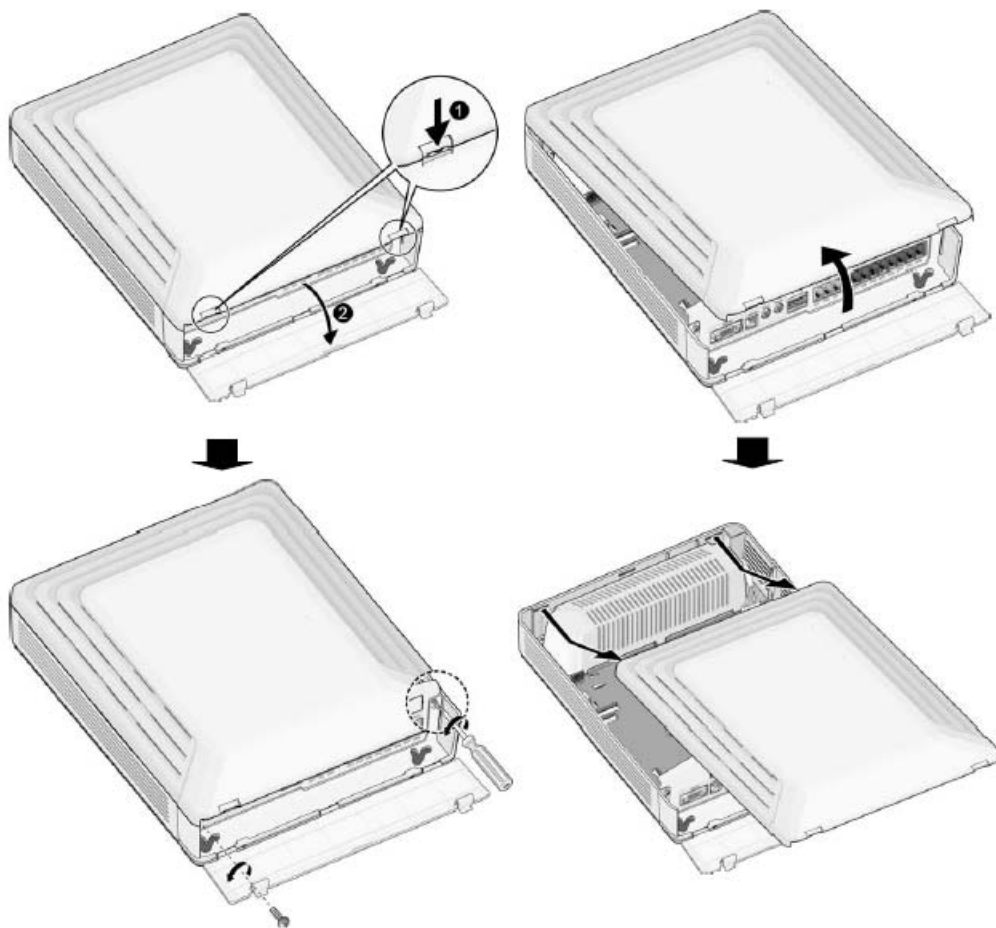

Figure 3-1 Opening the front cover

Closing the Front Cover

1. Insert the front cover into the slot on the KSU (as shown in [Figure 3-2](#)).
2. Put the front cover down on the KSU in the direction of the arrow shown.
3. Turn the screws clockwise to tighten and close the Cord Cover.



Figure 3-2 Closing the front cover

IMPORTANT: Prior to operation, the front cover of the SBX IP must be closed and the screws tightened.

Frame Ground Connection

It is very important that the frame of the SBX IP system is grounded:

1. Turn the grounding screw counter clockwise to loosen it (as shown in [Figure 3-3](#)).
2. Insert the grounding wire, and tighten the screw.
3. Connect the grounding wire to an appropriate ground source (refer to Caution below).

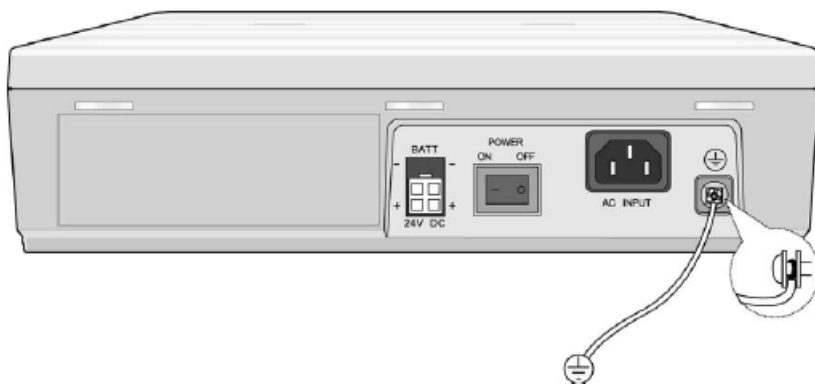

Figure 3-3 Grounding the KSU

CAUTION:

- The equipment should be connected to an outlet with a protective ground connection.
- For ground wire, green-and-yellow insulation is required. In addition, the cross-sectional area of the conductor must be more than UL 1015 AWG#18 (1.0mm). It is also recommended that the ground wire be shorter than 1m (3.28 ft).
- Proper grounding is very important to protect the SBX IP from external noise, and to reduce the risk of electrocution in the event of lightning strike.
- You must comply with applicable local regulations.

External Backup Battery Installation

In case of power failure, the external backup batteries automatically maintain uninterrupted power for the SBX IP system. The external batteries must provide 24V DC; this is generally accomplished by connecting two 12V batteries in a series arrangement (as shown in [Figure 3-4](#)).

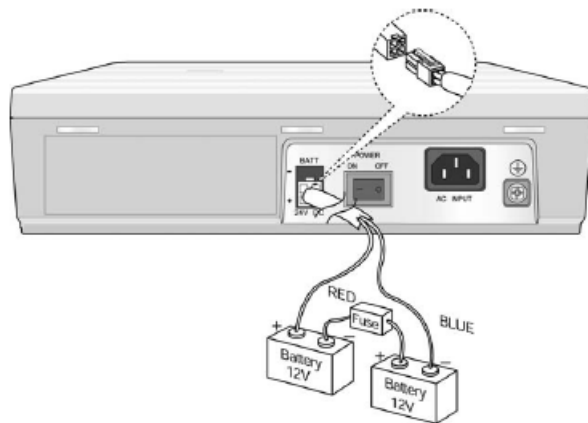

Figure 3-4 External Backup Battery Installation

NOTE: The cable used to connect the battery is supplied with the KSU.

Battery operation is controlled by the PSU. The PSU provides charging current to the batteries during normal AC power operation at a maximum of about 200mA. PSU battery operation is halted if the AC power is re-connected, or if the battery voltage is too low to maintain full-system operation. The external batteries maintains system operation as needed, depending on several elements such as battery charge status, condition and capacity of the batteries, and system configuration (that is, number of station ports).

CAUTION:

- It is recommended that you use an external backup battery fuse (5A @ 250V) between the battery and the system.
- The recommended battery capacity is 24V/20AH MF. The SBX IP system generally operates for over 3 hours with batteries that are in good condition.
- Carefully check the battery polarity with cable colors (red and blue) when connecting the battery to the system.
- Make sure that you do not short-out the external batteries and cables.
- There is a danger of explosion if external batteries are replaced incorrectly. Be sure replacement batteries are the same as (or equivalent to) those recommended by the manufacturer. Dispose of used batteries according to the manufacturer's instructions.

KSU Mounting

Wall Mounting

1. Install three (3) anchor plugs into the wall using the mounting template included for accurate placement, as shown in #1-#3 of [Figure 3-5](#).
2. Attach the mounting template with the three (3) screws (included) to the three (3) anchor plugs #4 of [Figure 3-5](#).
3. Hook the KSU onto the screws, making sure that the system slides down securely, as shown in [Figure 3-6](#).

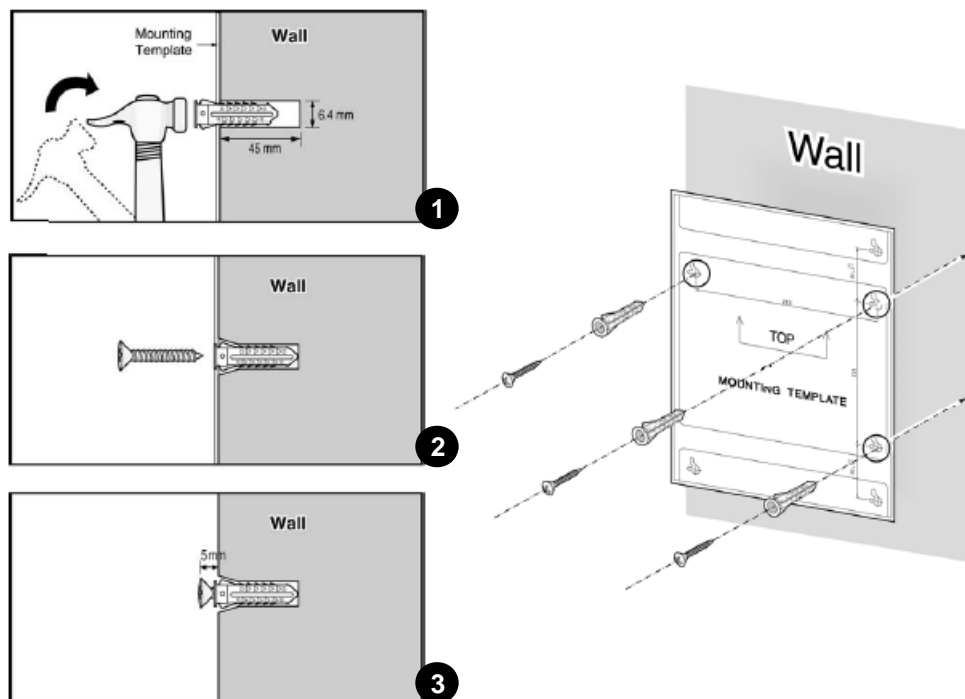

Figure 3-5 Mounting Template

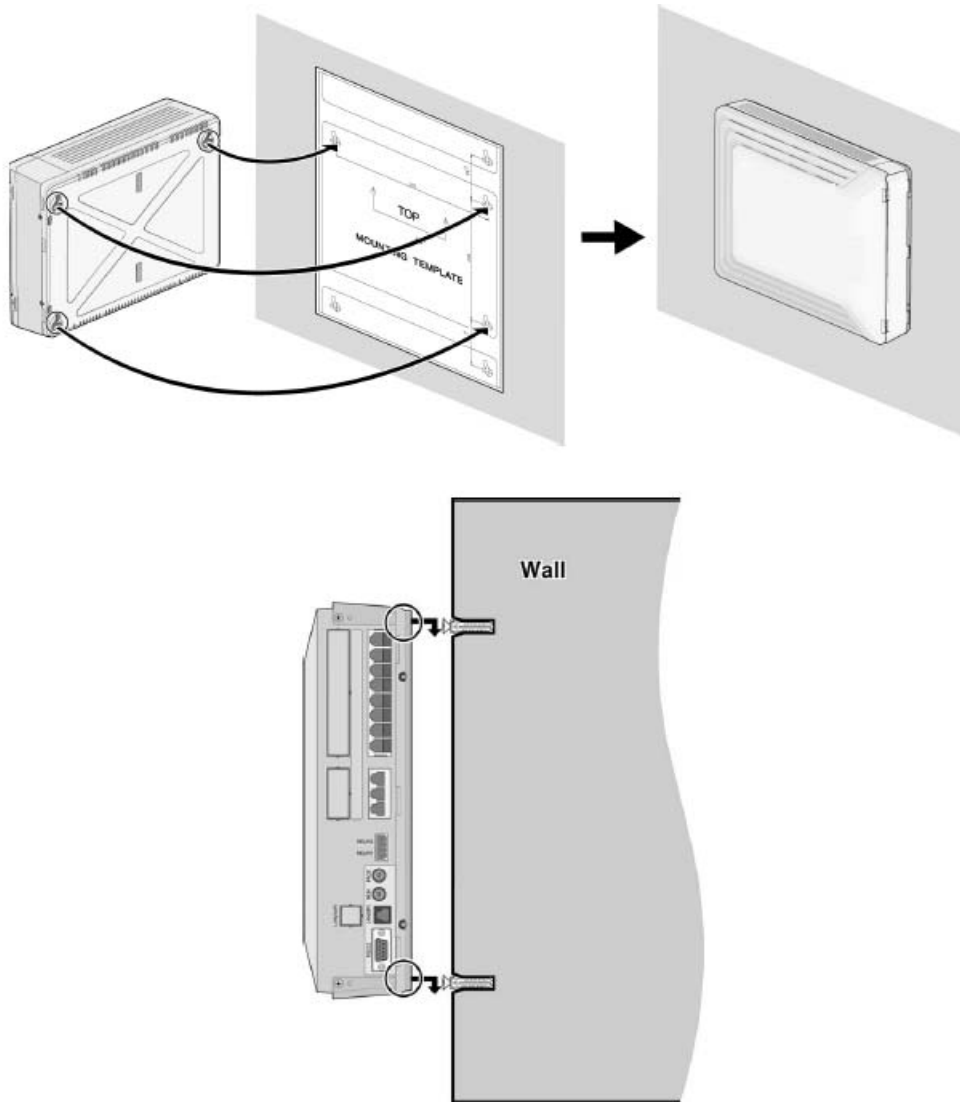

Figure 3-6 Wall Mounting the KSU

Desktop Mounting

To use the SBX IP system on top of a desk or other flat surface, use the following procedure:

1. To attach the rubber feet to the bottom of the SBX IP system as shown in [Figure 3-7](#), first remove the protective sticker from the rubber feet.
2. After attaching the rubber feet to the BKSU and EKSU, firmly mount the EKSU onto the BKSU.

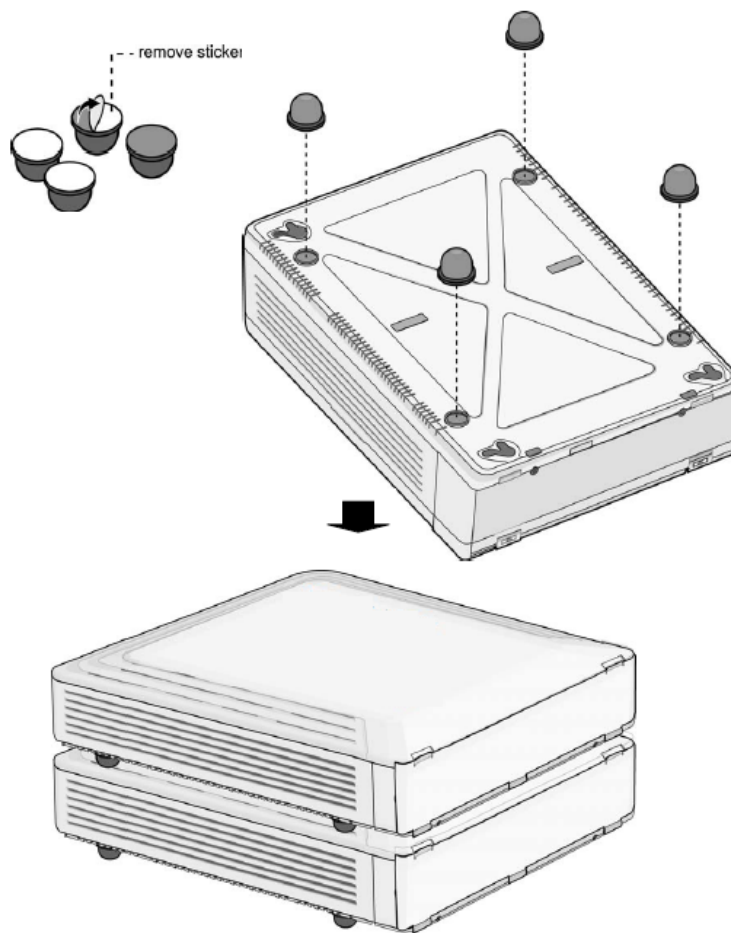

Figure 3-7 Desktop Mounting

Expansion KSU Installation

Unpacking

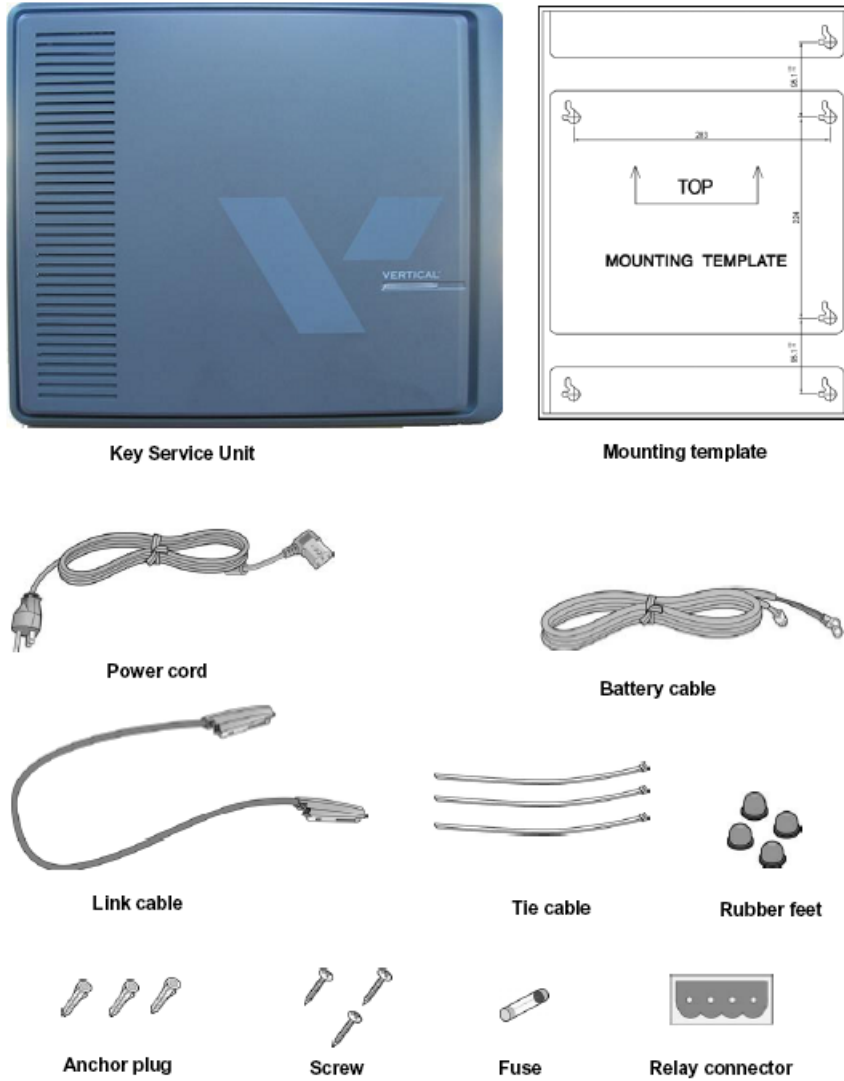

Figure 3-8 EKSU Carton Contents

Connecting the Expansion KSU to the Basic KSU

To connect the Expansion KSU to the Basic KSU, perform the following steps:

1. Remove the “dummy” of each KSU.
2. Use the link cable to connect the Basic KSU to the Expansion KSU (as shown in [Figure 3-9](#)).
3. To secure the link cable, turn the screw clockwise to tighten, and then tie the link cable with tie cable (as shown in [Figure 3-10](#)).

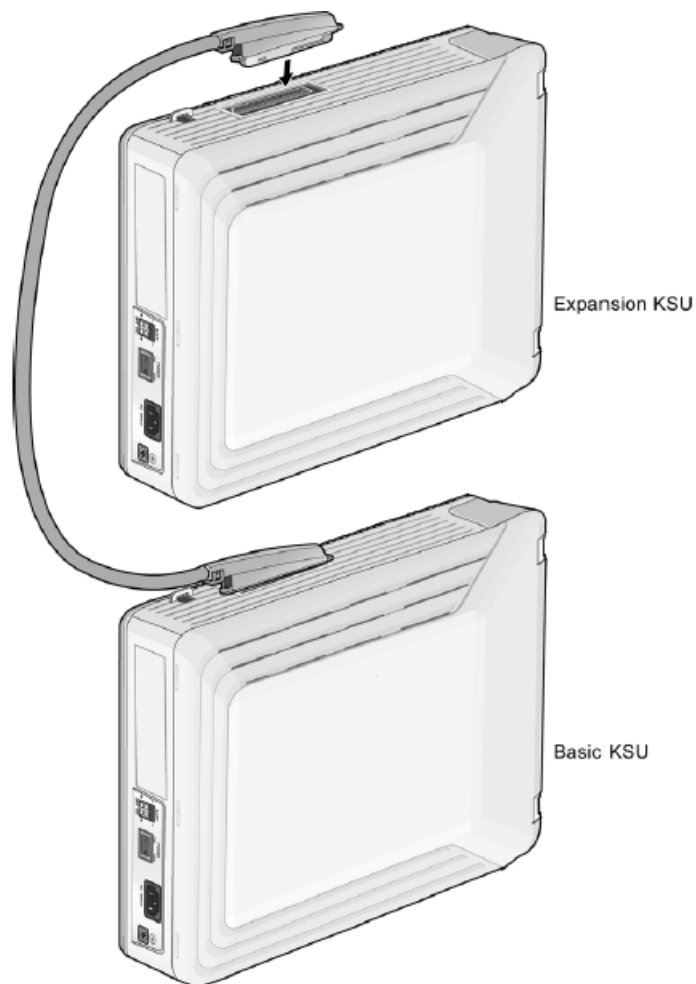

Figure 3-9 Connecting KSUs

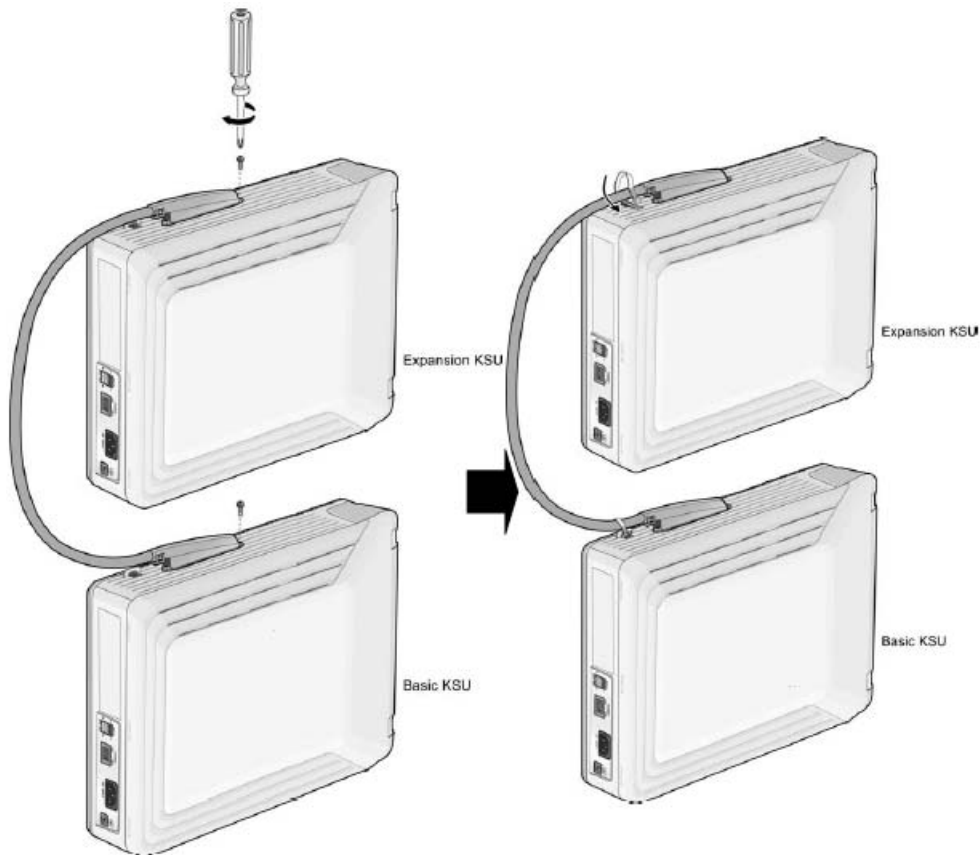

Figure 3-10 EKSU to BKSU Connection

NOTE:

- If AC power fails, the last SLT port on the EMBU automatically connects to CO1.
- If power to the EKSU is turned off while both systems (BKSU and EKSU) are working properly, the BKSU automatically restarts.

Expansion KSU Mounting

NOTE: Do not make any link cable connections between the BKSU and EKSU until they both are properly wall mounted or rack mounted.

EKSU Wall Mounting

1. Install the EKSU within 5 centimeters of the basic system.
2. Install three (3) anchor plugs into the wall using the mounting template included for accurate placement. The KSU can be mounted either vertically or horizontally.
3. Screw the included three (3) screws into the three (3) anchor plugs (as shown in [Figure 3-11](#)).

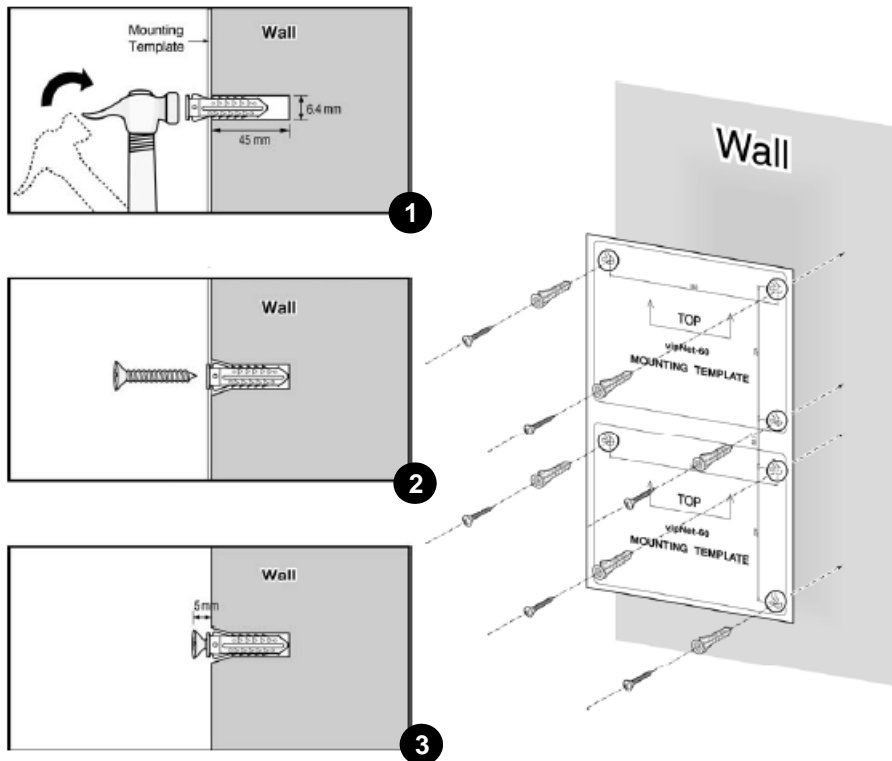

Figure 3-11 EKSU Mounting Template

- Hook the Expansion KSU onto the installed screws, making sure that the system slides down securely ([Figure 3-12](#).)

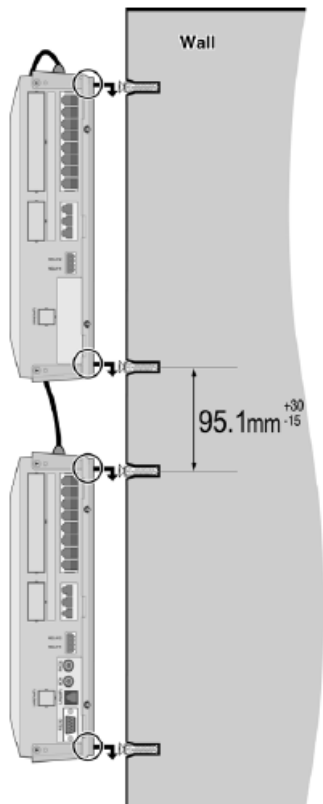

Figure 3-12 EKSU Wall Mounting

Board Installation

While installing boards, be aware of the following:

CAUTION:

- Power must be turned OFF before and during board installation.
- To protect the system from static electricity, do not touch the boards. To discharge static, touch a grounded object or wear a grounding strap.
- Insert the boards carefully to avoid bending connector pins (male pins on MBU/EMBU). Misaligning can damage the boards.

To install the board, perform the following steps:

- Before inserting the board, remove the dummy slot (as shown in #1 of [Figure 4-1](#)).
- Hold the board (as shown in #2 of [Figure 4-1](#)), and carefully insert the board in the direction of the arrow so that the board securely engages with the connector (CN2) on the main board (as shown in #3).

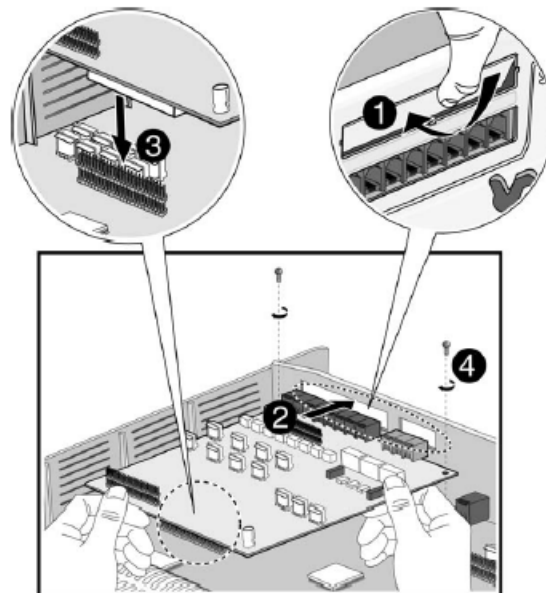

Figure 4-1 Board Installation

Basic Board Installations

Main Board Unit (p/n: 4000-00)

The MBU controls the communication between the peripheral interfaces, supervises all resources in the system, controls the gain adjustment of the PCM signal, generates the system tones, and manages system call processing.

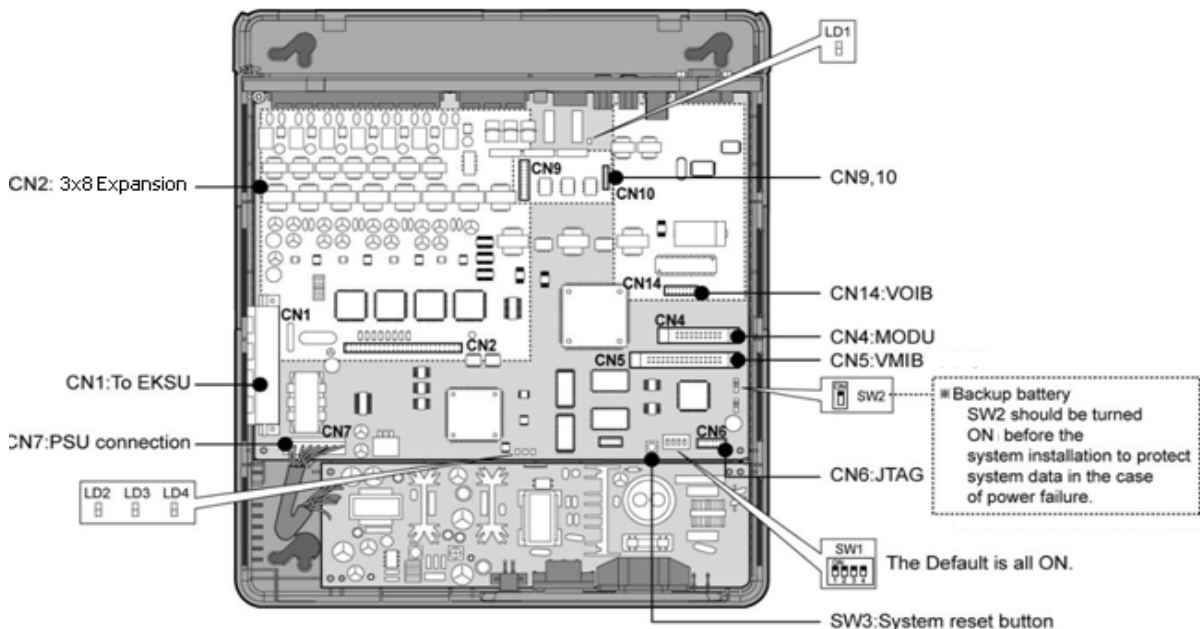

Figure 4-2 MBU

Main Board Unit (p/n: 4000-03)

This MBU performs all the same functions as the MBU shown above. This unit was modified to accommodate expanded capabilities such as the T1/PRI board and the 3x8 Expansion board.

(Also, this unit has been pre-loaded with the 3.0 software, or higher.)

NOTE: If AC power fails, the last SLT port on the MBU automatically connects to CO1.

The MBU is installed in the KSU, and it provides various types of connectors and RJ11 modular jacks for the connection of peripheral boards and miscellaneous functions (refer to [Figure 4-2](#), [Figure 4-3](#), and [Table 4-1](#)).

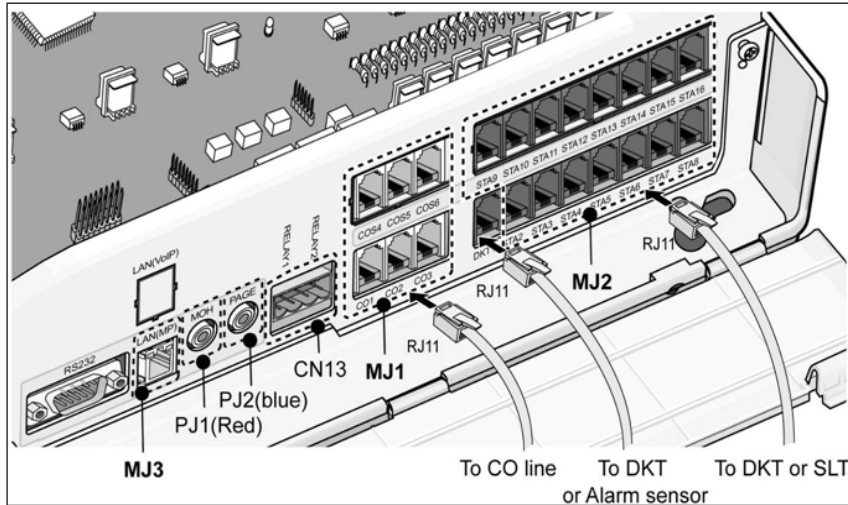

Figure 4-3 MBU Connection Ports

Table 4-1 Connectors

| SWITCH/CONNECTOR | FUNCTION | COMMENT |
|------------------|--|----------|
| CN1 | KSU Connection to EKSU with Link cable | 50 pins |
| CN2 | 3x8 Expansion Installation | 50 pins |
| CN4 | MODU Installation | 20 pins |
| CN5 | VMIB | 32 pins |
| CN6 | JTAG Port for Emulator | For Test |
| CN7 | PSU Connection (+5V, -5V, +30V) | 7 pins |
| CN8 | RS-232C Port Connection | 9 pins |
| CN13 | External Relay Contact | 4 pins |
| CN14 | VoIB Installation | 16 pins |



Table 4-1 Connectors (continued)

| SWITCH/CONNECTOR | | FUNCTION | COMMENT |
|------------------|---------|---|------------------|
| MJ1 | | 3 CO Lines Connection | 3 arrays |
| MJ2 | MJ2-1 | 1 DKT or Alarm Sensor | 8 arrays |
| | MJ2-2-8 | 7 DKTs or 7 SLTs Connection | |
| MJ3 | | LAN | 1 LAN |
| PJ1 (Red) | | External MOH Connection | |
| PJ2 (Blue) | | External Page Connection | |
| SW1 | | 4 Poles DIP Switch for Software Usage | Default = All ON |
| SW2 | | Lithium Battery ON/OFF Switch for Memory & RTC Backup | Default = OFF |
| SW3 | | System Reset Button | |
| SW4 | | JTAG Reset Enable/Disable Switch | Not Assembled |

Modular Jack (MJ1 - MJ3) Pin Assignment

MBU MJ1 (CO)

Table 4-2 MBU1 - 1, 2, 3

| CONNECTOR | PIN NUMBER | | SIGNAL NAME |
|---|--|------|-------------|
| RJ11  |  | 1, 2 | n/a |
| | | 3, 4 | CO-T, CO-R |
| | | 5, 6 | n/a |

MBU MJ2 (Extension)

Table 4-3 MBU MJ2 - 1 (DKT Only)





| CONNECTOR | PIN NUMBER | | SIGNAL NAME |
|--|---|------|-----------------|
| RJ11  |  | 1 | n/a |
| | | 2 | DKT-T |
| | | 3, 4 | Alarm_Detection |
| | | 5 | DKT-R |
| | | 6 | n/a |

Table 4-4 MBU MJ2 - 2, 3, 4, 5, 6, 7, 8

| CONNECTOR | PIN NUMBER | SIGNAL NAME | |
|--|---|-------------|--------------|
| RJ11  |  | 1 | n/a |
| | | 2 | DKT-T |
| | | 3, 4 | SLT-T, SLT-R |
| | | 5 | DKT-R |
| | | 6 | n/a |

NOTE: When installing DKTs or SLTs on Hybrid Ports (MJ2-2,3,4,5,6,7,8), keep the pin assignment (as shown above in [Table 4-4](#)). Otherwise the DKTs or SLTs will not operate normally.

Table 4-5 Terminal DKT





| CONNECTOR | PIN NUMBER | SIGNAL NAME | |
|--|---|-------------|-----------------|
| RJ11  |  | 1 | n/a |
| | | 2 | RING |
| | | 3, 4 | <i>Reserved</i> |
| | | 5 | TIP |
| | | 6 | n/a |

Table 4-6 Terminal SLT

| CONNECTOR | PIN NUMBER | SIGNAL NAME | |
|--|---|-------------|-----------|
| RJ11  |  | 1, 2 | n/a |
| | | 3, 4 | TIP, RING |
| | | 5, 6 | n/a |

CN13 Pin Assignment (Relay Contact)

Table 4-7 CN13



| CONNECTOR | NO | SIGNAL NAME |
|---|----|-----------------|
| 4 PIN  | 1 | Relay 1 - pin 1 |
| | 2 | Relay 1 - pin 2 |
| | 3 | Relay 2 - pin 1 |
| | 4 | Relay 2 - pin 2 |

Table 4-8 MJ3 Pin Assignment (LAN)

| CONNECTOR | PIN NUMBER | | SIGNAL NAME | FUNCTION |
|---|---|------------|-----------------|---------------|
| RJ45  |  | 4, 5, 7, 8 | <i>reserved</i> | |
| | | 1 | TX+ | Transmit Data |
| | | 2 | TX- | Transmit Data |
| | | 3 | RX- | Receive Data |
| | | 6 | RX+ | Receive Data |

Switch, LED, and Connector

Table 4-9 SW1 Functions

| SWITCH | FUNCTION | OFF | ON (DEFAULT) |
|--------|---|---------|--------------|
| 1-1 | Administration Programming Access | Disable | Enable |
| 1-2 | Command/Event Trace (Software Testing) | Enable | Disable |
| 1-3 | Simplified Message Desk Interface control (SMDI - Voice Mail) | SMDI ON | SMDI OFF |
| 1-4 | Database Default on Power Up | Disable | Enable |











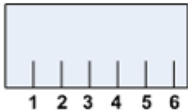















Before programming the system, Switch 1-4 (as shown above in [Table 4-9](#)) should be set to ON. The power should then be cycled OFF, and back ON to initialize the default system database. Once the database has been initialized, switch 1-4 should be placed in the OFF position to protect the database.

To protect the RAM/RTC data, set the SW2 lithium battery switch to the ON position, then install the option boards to the MBU.

CAUTION:

- The SW2-DIP switch should be set to the ON position to protect the system database in case of power failure.
- Replace the batteries (when needed) with the same or equivalent type recommended by the manufacturer. The system will not function normally if the batteries are replaced incorrectly.
- Dispose of used batteries according to manufacturer's instructions and/or local government regulations.
- After the system powers up and initializes, the 4th pole of SW1 should be set to the OFF to position to protect the features being programmed in Admin Programming.

SBX 25-Pair Installation Cable Pinouts

| Modular Connector/Pin # | 25 Pair Cable | BKSU FUNCTION | 3X8 HYBRID CARD FUNCTION | |
|---|--|--|--|--|
| <p>RJ 11 Connector Pins</p>  |  Pin 3  Pin 4 | WHITE/BLUE BLUE/WHITE | CO 1 | CO 1 |
| |  Pin 3  Pin 4 | WHITE/ORANGE ORANGE/WHITE | CO 2 | CO 2 |
| |  Pin 3  Pin 4 | WHITE/GREEN GREEN/WHITE | CO 3 | CO 3 |
| |  Pin 3  Pin 4  Pin 2  Pin 5 | WHITE/BROWN BROWN/WHITE WHITE/SLATE SLATE/WHITE | ALARM ALARM DKT 100 DKT 100 | SLT 100 SLT 100 DKT 100 DKT 100 |
| |  Pin 3  Pin 4  Pin 2  Pin 5 | RED/BLUE BLUE/RED RED/ORANGE ORANGE/RED | SLT 101 SLT 101 DKT 101 DKT 101 | SLT 101 SLT 101 DKT 101 DKT 101 |
| |  Pin 3  Pin 4  Pin 2  Pin 5 | RED/GREEN GREEN/RED RED/BROWN BROWN/RED | SLT 102 SLT 102 DKT 102 DKT 102 | SLT 102 SLT 102 DKT 102 DKT 102 |
| |  Pin 3  Pin 4  Pin 2  Pin 5 | RED/SLATE SLATE/RED BLACK/BLUE BLUE/BLACK | SLT 103 SLT 103 DKT 103 DKT 103 | SLT 103 SLT 103 DKT 103 DKT 103 |
| |  Pin 3  Pin 4  Pin 2  Pin 5 | BLACK/ORANGE ORANGE/BLACK BLACK/GREEN GREEN/BLACK | SLT 104 SLT 104 DKT 104 DKT 104 | SLT 104 SLT 104 DKT 104 DKT 104 |
| | Pin 3 Pin 4 Pin 2 Pin 5 | BLACK/BROWN BROWN/BLACK BLACK/SLATE SLATE/BLACK | SLT 105 SLT 105 DKT 105 DKT 105 | SLT 105 SLT 105 DKT 105 DKT 105 |
| | Pin 3 Pin 4 Pin 2 Pin 5 | YELLOW/BLUE BLUE/YELLOW YELLOW/ORANGE ORANGE/YELLOW | SLT 106 SLT 106 DKT 106 DKT 106 | SLT 106 SLT 106 DKT 106 DKT 106 |
| | Pin 3 Pin 4 Pin 2 Pin 5 | YELLOW/GREEN GREEN/YELLOW YELLOW/BROWN BROWN/YELLOW | SLT 107 SLT 107 DKT 107 DKT 107 | SLT 107 SLT 107 DKT 107 DKT 107 |

Expansion Main Board Unit (EMBU)

Expansion MBU (p/n: 4002-00)

The Expansion Main Board Unit provides the following features:

- DKT and SLT Interface circuits
- Ring Generation circuit
- External Relay contacts for LBC or general purpose
- Peripheral Device Decoding circuit
- Master Clock Generation circuit
- PFT circuit [CO1 ↔ the last SLT port (STA8)]
- PCM Voice Processing circuit with ACT2 (ASIC, voice switching including DSP) device for PCM tone generation and PCM gain control.

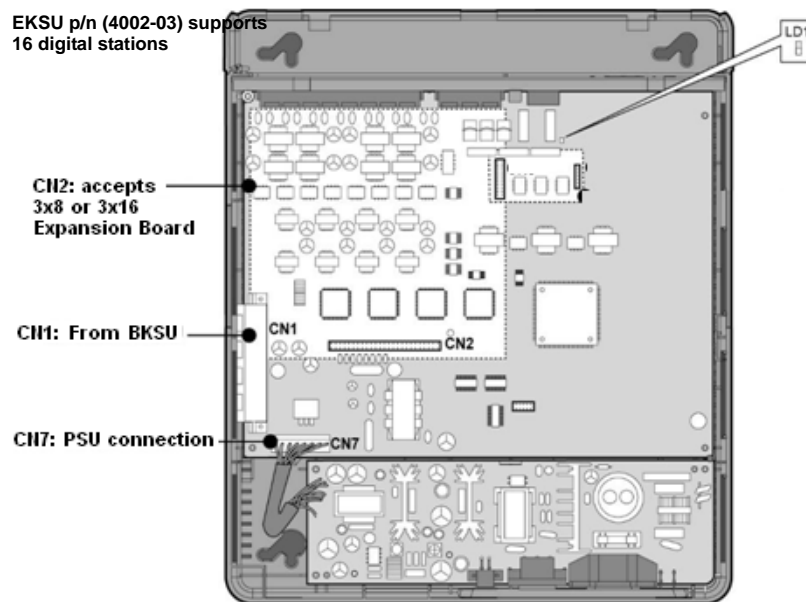

Figure 4-4 EMBU

Expansion MBU (p/n: 4002-03)

This "all digital" EMBU provides the same features and functionality as the EMBU described above. This unit was modified to accommodate expanded system capabilities such as the DTIB16 card which supports 16 digital stations.

NOTE:

- If AC power fails, the last SLT port on the EMBU automatically connects to CO1.
- If power to the EKSU is turned off while both systems (BKSU and EKSU) are working properly, the BKSU automatically restarts.

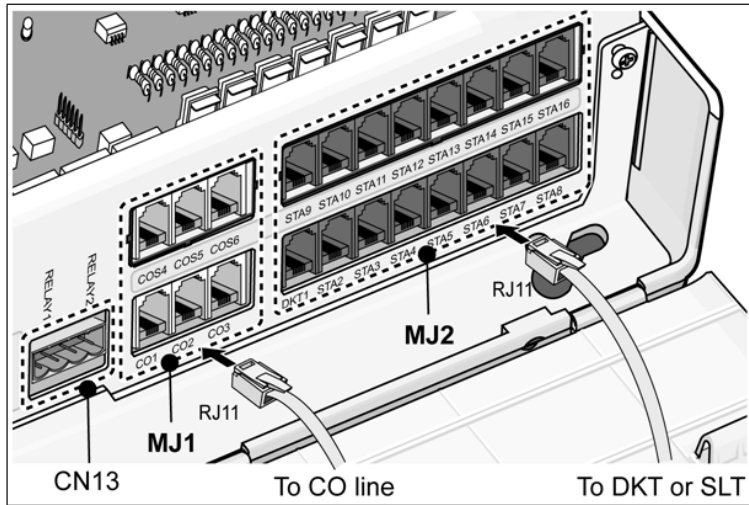

Figure 4-5 EMBU Connection Ports

Table 4-10 Connector/Modular Jack/Switch Functions

| SWITCH/CONNECTOR | FUNCTION | COMMENT |
|------------------|---|----------|
| CN1 | KSU Connection from BKSU with Link cable | 50 Pins |
| CN2 | CO and Extension Board (3x8 Expansion) installation | 50 Pins |
| CN7 | PSU connection | 7 Pins |
| CN13 | External Relay contact | 4 Pins |
| MJ1 | 3 CO connection | 3 Arrays |
| MJ2 | 16 DKT | 8 Arrays |

Table 4-11 LED Indications

| LED | DESCRIPTION |
|-------------|---|
| LED1 (Blue) | Periodic Toggle - ON, 300 msec; OFF, 300 msec |

Modular Jack (MJ1 - MJ3) Pin Assignment

EMBU MJ1(CO)

Table 4-12 EMBU MJ1 - 1, 2, 3





| CONNECTOR | PIN NUMBER | SIGNAL NAME | |
|--|---|-------------|------------|
| RJ11  |  | 1, 2 | n/a |
| | | 3, 4 | CO-T, CO-R |
| | | 5, 6 | n/a |

Table 4-13 EMBU MJ2 - 1, 2, 3, 4, 5, 6, 7, 8

| CONNECTOR | PIN NUMBER | SIGNAL NAME | | |
|--|---|--------------------|--------------|------|
| RJ11  |  | 1 | n/a | |
| | | 2 | DKT-T | |
| | | 3, 4 | SLT-T, SLT-R | |
| | | 5 | DKT-R | |
| | | 6 | n/a | |
| | | Rel. 3.0 -----> | 2 & 5 | DKT1 |
| | | | 3, 4 | DKT2 |

NOTE: When installing DKTs or SLTs on Hybrid Ports, (MJ2 -2,3,4,5,6,7,8), keep the pin assignment (as shown above in [Table 4-13](#)). Otherwise the DKTs or SLTs will not operate normally.

Table 4-14 Terminal DKT





| CONNECTOR | PIN NUMBER | SIGNAL NAME | |
|--|---|-------------|-----------------|
| RJ11  |  | 1 | n/a |
| | | 2 | RING |
| | | 3, 4 | <i>reserved</i> |
| | | 5 | TIP |
| | | 6 | n/a |

Table 4-15 Terminal SLT

| CONNECTOR | PIN NUMBER | SIGNAL NAME | |
|--|---|-------------|-----------|
| RJ11  |  | 1, 2 | n/a |
| | | 3, 4 | TIP, RING |
| | | 5, 6 | n/a |

CN13 Pin Assignment (Relay Contact)

Table 4-16 CN13

| CONNECTOR | NO | SIGNAL NAME |
|---|----|-----------------|
| 4 PIN  | 1 | Relay 1 - pin 1 |
| | 2 | Relay 1 - pin 2 |
| | 3 | Relay 2 - pin 1 |
| | 4 | Relay 2 - pin 2 |

CO Line and Extension Boards

3x8 Expansion Board (3 CO Line and 8 Hybrid)

The 3x8 Expansion Board can be installed on the CN2 connector of the MBU or EMBU, and provides three (3) CO/PBX Loop Start CO Line interfaces that support Pulse/DTMF signaling. Each interface contains ring and loop current circuits, A/D and D/A conversions, as well as pulse signaling circuitry.

This board also provides eight Hybrid ports (eight DKTs or eight SLT interfaces), and can detect FSK signal for incoming Caller ID, DTMF signal for incoming caller ID, and a call progress tone. It also provides three (3) on-hook connection paths for CID/SMS.

| BOARD | LINE | CONNECTOR TYPE | DESCRIPTION | CABLE |
|---------------|-----------------------|----------------|----------------------------------|----------------------------------|
| 3x8 Expansion | 3 CO & 8 SLT or 8 DKT | RJ11 | 3 CO Line and 8 Hybrid Interface | DKT : 4 wire CO, SLT : 2 wire |

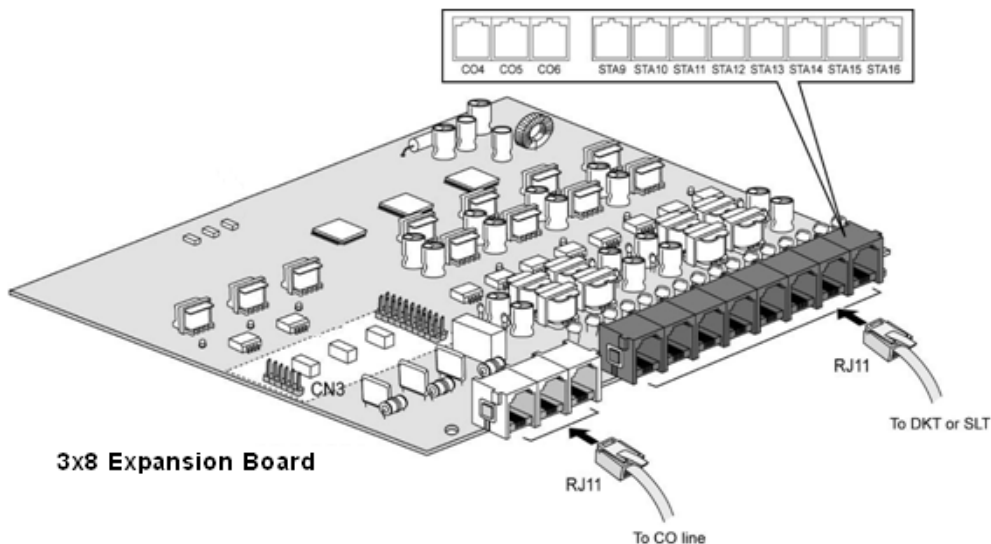

Figure 4-6 3x8 Expansion Board

Modular Jack (MJ1-MJ2) Pin Assignment

Table 4-17 3x8 Expansion Board MJ1 - 1, 2, 3





| CONNECTOR | PIN NUMBER | SIGNAL NAME | |
|--|---|-------------|------------|
| RJ11  |  | 1, 2 | n/a |
| | | 3, 4 | CO-T, CO-R |
| | | 5, 6 | n/a |

Table 4-18 3x8 Expansion Board MJ2 - 1, 2, 3, 4, 5, 6, 7, 8

| CONNECTOR | PIN NUMBER | SIGNAL NAME | |
|--|---|-------------|--------------|
| RJ11  |  | 1 | n/a |
| | | 2 | DKT-T |
| | | 3, 4 | SLT-T, SLT-R |
| | | 5 | DKT-R |
| | | 6 | n/a |

3x16 Expansion Board (3 CO Line and 16 Digital)

IMPORTANT: The 3x16 Expansion Board can ONLY be installed on the “modified” MBU (p/n 4000-03) or EMBU (p/n 4002-03)

The 3x16 Expansion Board can be *optionally* installed on the CN2 connector of the “modified” MBU or EMBU, and provides three (3) CO/PBX Loop Start CO Line interfaces that support Pulse/DTMF signaling. Each interface contains ring and loop current circuits, A/D and D/A conversions, as well as pulse signaling circuitry.

This board also provides 16 Digital ports (16 DKT interfaces), and can detect FSK signal for incoming Caller ID, DTMF signal for incoming caller ID, and a call progress tone. It also provides three (3) on-hook connection paths for CID/SMS.

| BOARD | LINE | CONNECTOR TYPE | DESCRIPTION | CABLE |
|----------------|---------------|----------------|------------------------------------|-----------------------------|
| 3x16 Expansion | 3 CO & 16 DKT | RJ11 | 3 CO Line and 16 Digital Interface | DKT : 4 wire CO : 2 wire |

NOTE: The modular jack pin assignments are the same as the 3x8 Expansion Board, see [Table 4-17](#) and [Table 4-18](#) above.

Other Board Installations (optional)

Digital Telephone Interface Board (DTIB16)

The Digital Telephone Interface Board (DTIB) can be *optionally* installed to provide digital voice and data communications to/from 16 digital telephones. An RJ11 type female connector is mounted on the front edge of the board for connection to the station interfaces.

- The EMBU (p/n 4002-03) can support two DTIB16 boards to increase the number of ports to 32.
- Notice the board-specific pinouts shown in [Figure 4-7](#).
- The DTIB16 is configured in PGM 101-103.

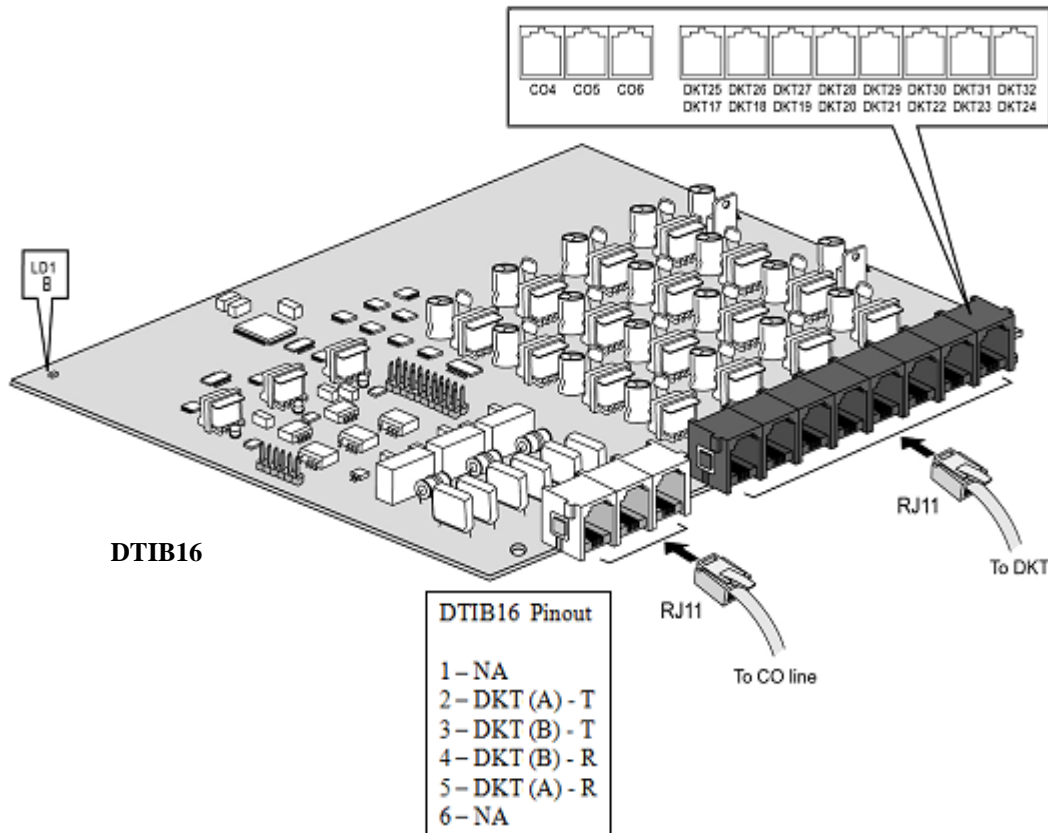

Figure 4-7 Installation of the DTIB16 Board

Modem Function Unit (MODU)

MODU provides analog modem connection. The MODU can be *optionally* installed on the MODU connectors (CN4) of the MBU. The MODU supports Bell, ITU-T, V.34, V.32BIS, and V.90 protocols at a speed rate of 300bps up to 33Kbps. It also supports automatic rate negotiation.

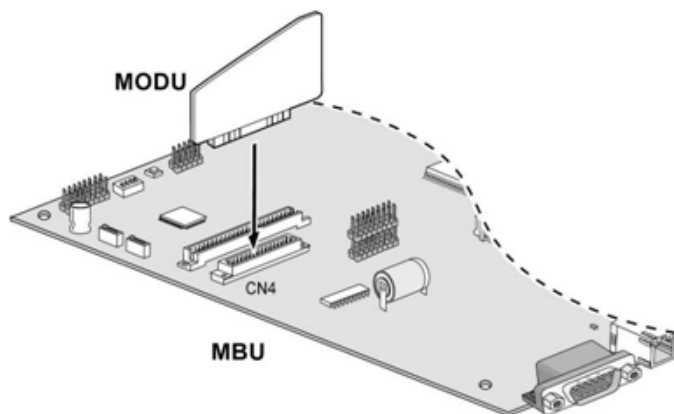

Figure 4-8 Installation of the MODU Board

T1/PRI Interface Board

The T1/PRI interface board provides a full T1/PRI digital trunk interface and 8 hybrid stations. The board also supports both full and fractional T1/PRI circuits in clusters of 4.

This interface supports either 24 PCM channels for T1 or 23 PCM channels for PRI. Nine (9) loop start CO lines can be used in addition to the T1/PRI channels. The T1/PRI includes the Ethernet port.

This board can be used as either a T1 or a PRI by changing the onboard DIP switch. By default, switch SW4 is set to the ON position (PRI).

CAUTION: The T1/PRI board can only be used with MBU p/n: 4000-03.

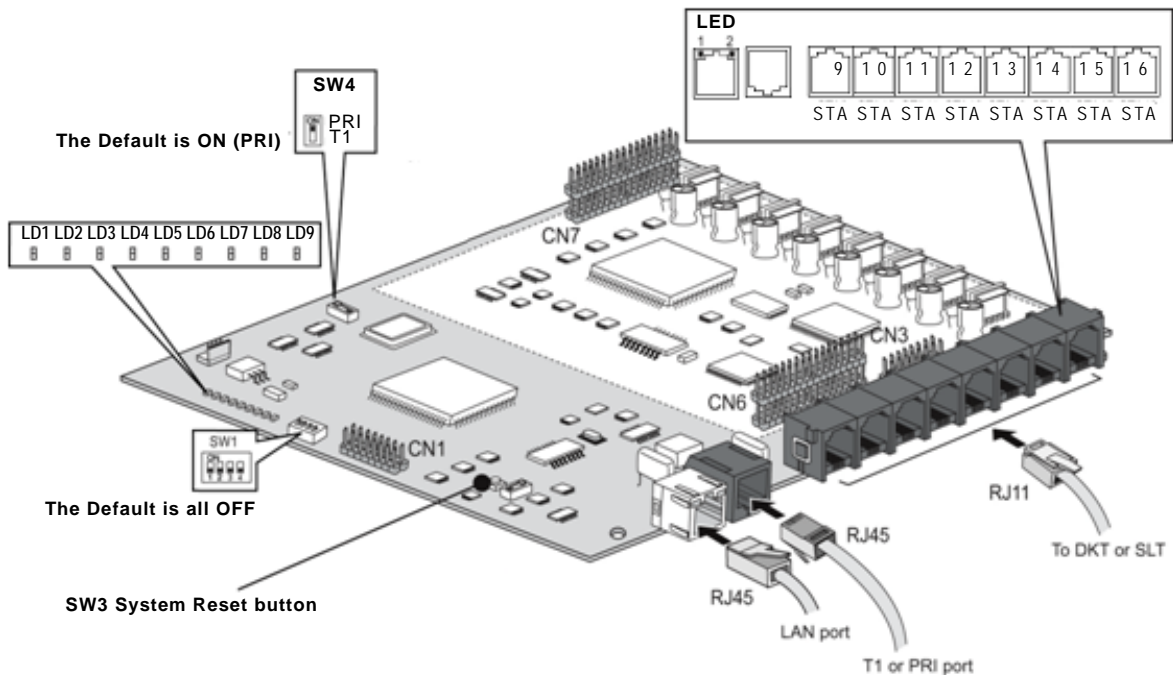

LED Indications

| LED | SPECIFICATION |
|--------|---|
| LED1 | PRI - In Use and blinking slowly if active T1 - In Use |
| LED2 | ON - RX Carrier Loss |
| LED3 | ON - Out of frame |
| LED4 | ON - Yellow Alarm |
| LED5 | ON - RX all 1 |
| LED6 | ON - Loop back mode |
| LED7 | PRI - ON: Multiframe Establish Alarm T1 - ON: Blinking slowly if active |
| LED8 | ON - reserved |
| LED9 | ON - TE |
| LED10* | Blue ON - In Use of one of 8 HYBRID extensions of PRHB8 board * LED 10 is not related to PRI/T1 trunk operation. It is only related to 8 extensions use state of PRHB8 board |

VoIB -- Voice Over Internet Protocol Board (4ch)

The VoIB can be *optionally* installed on the MBU, and provides four VoIP channels.

The length of the Ethernet cable should be less than ten (10) meters.

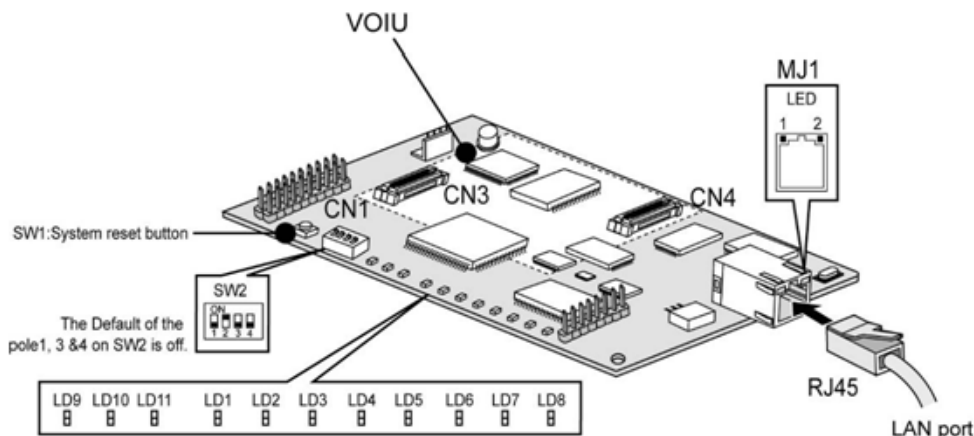

Figure 4-9 VoIB

The VoIB can be installed on the basic MBU, and provides the Ethernet interface for software applications and VoIP features with an optional VoIP daughter board.

The VoIB has the capacity for maximum four (4) channels with one (1) VoIB. The VOIU provides an additional four (4) VoIP channels.

| ITEM | SPECIFICATION |
|--|---|
| LAN Interface | 10 Base-T Ethernet (IEEE 802.3) |
| Speed | 10/100 auto-negotiation, 100 Mbps recommended |
| Duplex | Half Duplex or Full Duplex (Auto-Negotiation) |
| VoIP Protocol | H.323 Revision 4 |
| Voice Compression | G.711/G.726/G.729/ G.723.1 |
| Voice/Fax Switching | T.38 |
| Echo Cancellation | G.165 |
| Dual SIP / H.323 protocol support | -- |
| ITU-T H.323 v4 & H.450 standard compliance | Supports H.323 fast connect, early H.245, and H.245 tunneling Supports H.323 Gatekeeper register, direct and route calls Inband / out of band DTMF transmission |

| ITEM | SPECIFICATION |
|--|---|
| SIP RFC 2543/3261 standard compliance | Supports Inband / RFC 2833 / Out of band (INFO) DTMF transmission |
| Supports IPKTS Protocol for Vertical IP phones | -- |
| Codecs | G.711A/u-law, G.723.1(5.3k/6.3k), G.729/G.729A |
| NAT friendly for IP phones | -- |



Various switch and connector functions

| SWITCH/CONNECTOR | FUNCTION |
|------------------|--|
| SW1 | VoIB Reset Switch for CPU (S32510A) |
| SW2 | Pole 2: Boot mode selection, others: reserved. Default: Pole 2 (ON), Others (OFF) |
| CN1 | JTAG (Joint Test Action Group) for debug |
| CN2 | RS-232C Trace Tool Connection |
| CN3 and CN4 | VOIU Board Connection |
| CN5 | MBU Connection |
| MJ1 | Network (RJ-45) Cable Connection |

| LED | SPECIFICATION |
|------------------------|---|
| LED1 (yellow) | Channel1 seize indication LED (ON:Busy, OFF:Idle) |
| LED2 (yellow) | Channel2 seize indication LED (ON:Busy, OFF:Idle) |
| LED3 (yellow) | Channel3 seize indication LED (ON:Busy, OFF:Idle) |
| LED4 (yellow) | Channel4 seize indication LED (ON:Busy, OFF:Idle) |
| LED5 (yellow) | Channel5 seize indication LED (ON:Busy, OFF:Idle) |
| LED6 (yellow) | Channel6 seize indication LED (ON:Busy, OFF:Idle) |
| LED7 (yellow) | Channel7 seize indication LED (ON:Busy, OFF:Idle) |
| LED8 (yellow) | Channel8 seize indication LED (ON:Busy, OFF:Idle) |
| LED9 (red) | VOIU DSP operation status LED (ON: Normal, OFF: Fail) |
| LED10 (red) | VoIB DSP operation status LED (ON: Normal, OFF: Fail) |
| LED11 | DSP HINT interrupt LED (ON: Active, OFF: Idle) |
| MJ1-LD2 (yellow) | Speed Status LED (OFF: 10Mbps) |
| MJ1-LD1 (green/orange) | Link Status LED (ON: Link, Flashing: Data Transfer) |

Pin assignment

Table 4-19 MJ3 Pin Assignment (LAN)

| CONNECTOR | PIN NUMBER | SIGNAL NAME | FUNCTION | |
|---|---|-------------|----------|---------------|
| RJ45  |  | 4, 5, 7, 8 | RESERVED | |
| | | 1 | TX+ | Transmit Data |
| | | 2 | TX- | Transmit Data |
| | | 3 | RX- | Receive Data |
| | | 6 | RX+ | Receive Data |

NOTE: 10BASE-T runs on Category 5 UTP or higher.

VOIU -- Internet protocol unit (4ch)

The VOIU can be *optionally* installed on the VoIB. It provides four (4) VoIP channels.

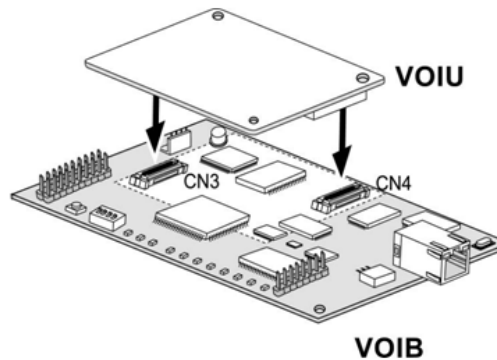

Figure 4-10 Installation of the VOIU Board

Voice Mail Interface Board (VMIB)

The Voice Mail Interface Board (VMIB) can be *optionally* installed on CN5 of the MBU. It provides the capability for system announcements, UCD announcements, and user greetings.

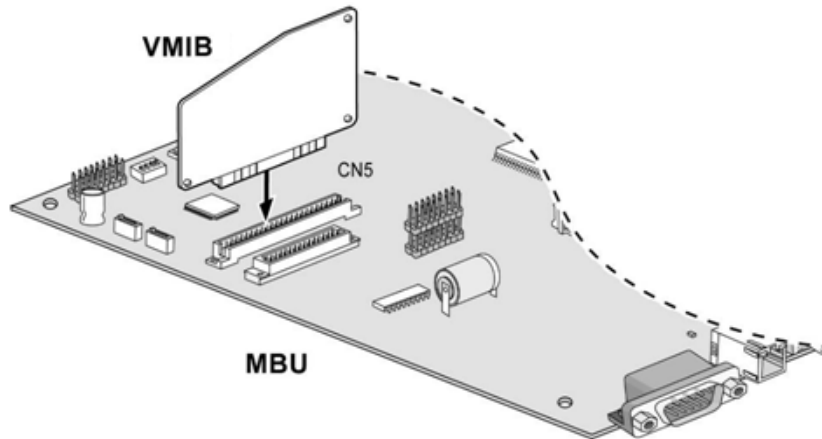

Figure 4-11 Installation of the VMIB Board

Table 4-20 Voicemail Specifications

| ITEM | 2-hour VMIB | 8-hour VMIB |
|---|-------------|-------------|
| Channel | 4 Channels | 4 Channels |
| Max Record Time: | | |
| Prompt | 8 Min. | 10 Min. |
| System Greeting (announcement) | 24 Min. | 40 Min. |
| User Record Time | 99 Min. | 480 Min. |
| Max Number of User Voice Messages | 800 | 800 |
| Number of system greeting (for all users in system) | 01-70 | 01-70 |

NOTE: MBU SW1-4 and SW2 control the protection of recorded messages.

NOTE: You can tell the 8-hour VMIB from the 2-hour VMIB by checking the label on the VMIB. The 8-hour VMIB is labeled 4000-80.

Terminal Connection and Wiring Method

Terminal and Doorbox Models

| MODEL | DESCRIPTION |
|-------|-----------------------------|
| 7208D | 8-button digital telephone |
| 7224D | 24-button digital telephone |
| -- | 48-button DSS Console |
| -- | 2-port digital Doorbox |



7208D

Figure 5-1 Vertical 7208 Telephone for SBX IP



7224D

Figure 5-2 Vertical 7224 Telephone for SBX IP

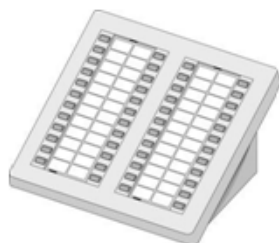

DSS



Doorbox

Figure 5-3 Vertical DSS and Doorbox for SBX IP

Terminal Cabling Distance

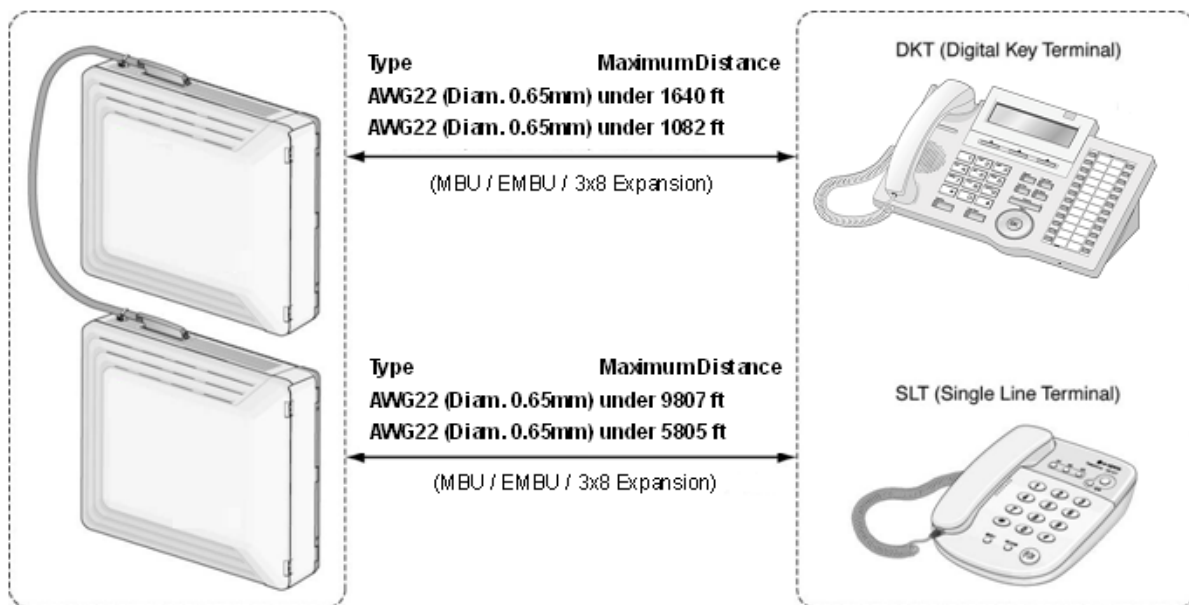

Figure 5-4 Terminal Cable Distance

Basic Terminal Connection

DKT and DSS

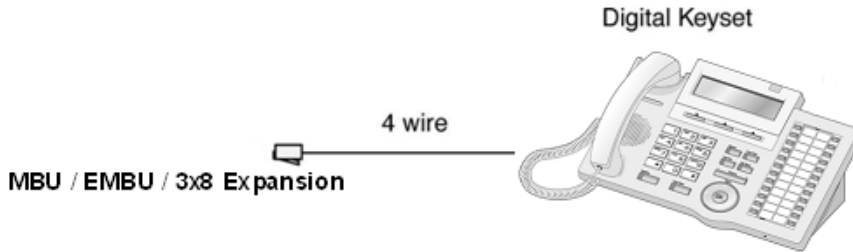



Figure 5-5 Connecting a DKT to the system

Table 5-1 DKT and DSS Connection Pin Assignment

| CONNECTOR | PIN NUMBER | NO | SIGNAL NAME |
|--|---|------|-------------|
| RJ11  |  | 1 | n/a |
| | | 2 | DKT-T |
| | | 3, 4 | Reserved |
| | | 5 | DKT-R |
| | | 6 | n/a |

SLT

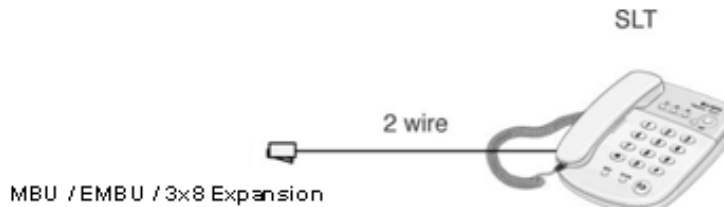



Figure 5-6 Connecting an SLT to the system

Table 5-2 SLT Connection Pin Assignment

| CONNECTOR | PIN NUMBER | NO | SIGNAL NAME |
|--|---|------|-------------|
| RJ11  |  | 1, 2 | n/a |
| | | 3, 4 | TIP, RING |
| | | 5, 6 | n/a |

Doorbox

The Doorbox is an intercom unit that can be installed at the entrance to a building for communication between visitors and employees inside.

By pressing a CALL button, a visitor can communicate with a person inside the building who has a phone with a “call coverage” flex button associated with the Doorbox.

Installation

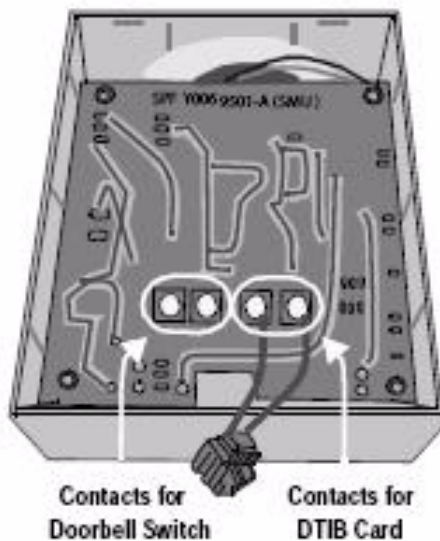

Operating Instructions

The following examples describe how calls are handled when sent through the Doorbox.

Call FROM the Doorbox

A visitor can press the CALL button once or the External switch once, depending on the setup.

- The visitor hears music from the Doorbox until station user answers the call.
- The station with the call coverage flexible button associated with the Doorbox also rings, and the call coverage button LED illuminates.

HINT: Refer to the Programming Guide ("Intercom Box Signaling" in Station Attributes).

- The station user answers the call by going off-hook using the handset or by pressing the SPEAKER button for speakerphone operation.

Call TO the Doorbox

The station user can go off-hook and press a flexible button that is pre-programming with the Doorbox station number, or dial the number associated with the doorbox.

Connecting Additional Terminals

The MBU provides connections for one external music source, one external page port, one relay contact, and an alarm detection input monitor through the PJ1 (RED, External MOH) and PJ2 (BLUE, External MOH) audio jacks and an MJ3 (RJ11 Modular Jack) as shown in [Figure 5-7](#).

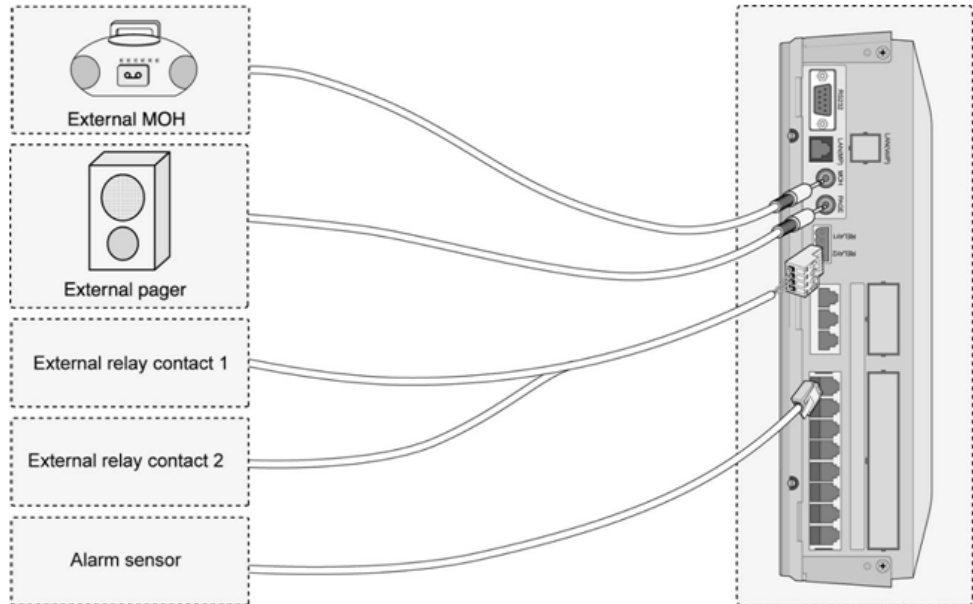

Figure 5-7 Adding Terminals

External Music Source Wiring

The MBU accommodates one external music port through a PJ1 (RED) audio jack.

Relay Contacts

The MBU/EMBU provides two (2) relay contacts that are used for a loud bell or other general purposes through pin No. 1-4 of CN13.

External Paging Port Wiring

The MBU supports one external paging port through a PJ2 (BLUE) audio jack.

Alarm Detection Wiring

The MBU provides an external alarm detection input, which can be used to transmit notification to extensions when the external switch is closed or opened (programmable through Admin Programming). This alarm detection input is provided through MJ2-1 pin 3-4 of the MBU.

Cable Wiring

Wall Mount Wiring

To install wall mount wiring, perform the following steps:

1. Make sure that the BKSU and EKSU have been installed correctly (see [Chapter 3 - KSU Installation](#)).
2. Connect cables to CO/STA and MOH/RS-232C ports, as shown in [Figure 5-8](#).
3. Connect the power cord and the battery cable.
4. Remove plastic filter pieces.
5. Using the tie cable provided, tie all the cables and the power cord (as appropriate) through the tie slot at the bottom-right side of the KSUs.
6. Close the covers of the KSUs, then close the cord cover.

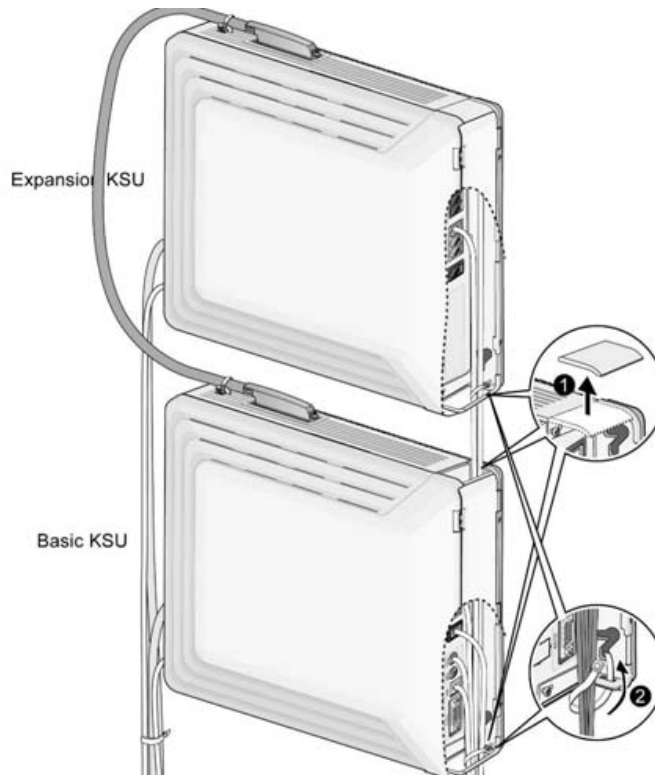

Figure 5-8 Wall Mount Wiring

Rack Mount Wiring

1. Check that the BKSU and EKSU have been installed correctly (see [Chapter 3 - KSU Installation](#)).
2. Connect cables to the CO/STA and MOH/RS-232C ports, as shown in [Figure 5-9](#).
3. Connect the power cord and the battery cable.
4. Remove the plastic filter pieces.
5. Using the tie cable provided, tie all the cables and the power cord (as appropriate) through the tie slot at the bottom-right side of the KSUs.
6. Close the covers of the KSUs and close the cord cover.

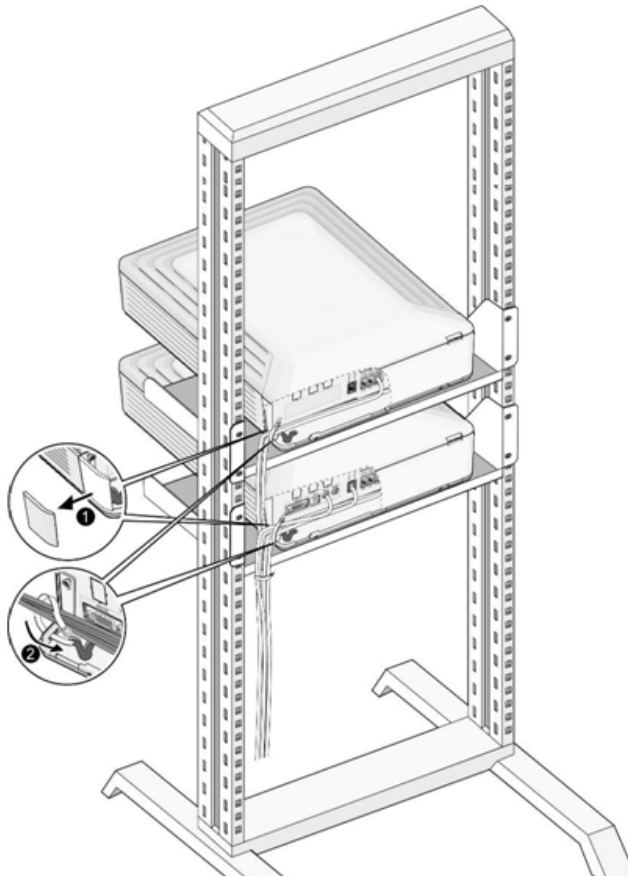

Figure 5-9 Rack Mount Wiring

IP Phones on the SBX IP

Supported IP phones:

- IP7008D, IP7024D, IP7024LD
- Nomad IP (Wireless)
- Nomad SP (Soft Phone)

NOTE: This section specifically applies to setting up the IP7000-series telephones only.

Minimum requirements

System

- SBX IP system with VoIP card
 - Static IP address for VoIP card. If NAT is used, it must be a 1-to-1 NAT
 - Separate IP address for the KSU's LAN port for system administration
- NOTE:** No VoIP communication takes place on the KSU LAN port.
- KSU version 1.0Cf
 - VoIP card software version B.1Dq.

Installed Environment

- CAT5E (or higher) patch cords from VoIP card to LAN switch
- No hubs
- Adequate bandwidth for the anticipated number of H.323 VoIP calls

IP endpoint licensing

Nomad SP requires a per-seat license. Two seats are automatically included; you do not have to install activation codes for these two seats.

IP7000 series and NomadIP wireless phones do not require a license.

NOTE: Entering IP address information to the KSU database from a digital phone is performed differently from programming IP settings for an IP remote phone.

Digital stations on KSU: Enter digits in groups of 3, with no punctuation or decimal.

Example: To program the address 192.168.1.3, dial 192168001001

IP phone: Enter digits with an asterisk [*] as the decimal.

Example: To program the address 192.168.1.10, dial 192*168*1*10

IP Addressing

To begin, obtain IP addresses from the network administrator for the location in which you are setting up the SBX IP system. Note them in the table provided below for reference while programming the system:

Table 5-3 IP Addresses for current system

| | VoIP card (VoB) | KSU LAN port | IP Phone (may be DHCP) | Your PC (may be DHCP) |
|-----------------|------------------------|---------------------|----------------------------------|---------------------------------|
| IP Address | | | | |
| Subnet Mask | | | | |
| Default Gateway | | | | |

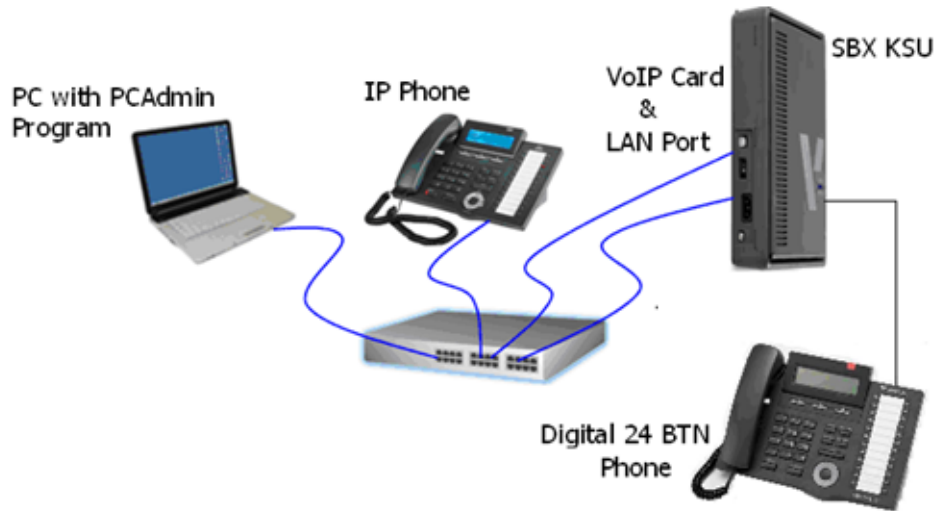

Figure 5-10 System Setup

- You will also need a 24-button SBX digital telephone to set up the system.
- For a typical test-bench or demonstration setup, you need 4 connections to a LAN switch, each via a straight-through CAT5E patch cord as shown in [Figure 5-10](#).
- You may use the IP address information shown in [Table 5-4](#) to set up a closed demo of the IP phone.

NOTE: These addresses will not function in a wide-area network or the Internet. They are for testing and demonstration purposes only:

Table 5-4 IP Addresses for testing and demonstration only

| | VoIP card | KSU LAN port | IP Phone | Your PC |
|-----------------|---------------|---------------|---------------|---------------|
| IP Address | 192.168.1.4 | 192.168.1.3 | 192.168.1.5 | 192.168.1.2 |
| Subnet Mask | 255.255.255.0 | 255.255.255.0 | 255.255.255.0 | 255.255.255.0 |
| Default Gateway | 192.168.1.1 | 192.168.1.1 | 192.168.1.1 | 192.168.1.1 |

Preparation

1. Before starting, verify that the VoIP (VoB) card is installed into the system properly (see [page 4-18](#)), and that the card is recognized in the KSU database.
2. KSU DIP switches must be set to enable the system to retain programming changes.
3. Set the PC IP address, default gateway, and subnet mask as noted in [Table 5-3](#).
4. Set the KSU's IP addressing using PGM 108 when logged into KSU administration from the 24-button digital attendant station (Station 100 by default). This assigns the IP address to the KSU's LAN port. The configuration for the VoIP card begins here.

PCAdmin Connection

Follow the PCAdmin User's Guide or the Tech Tip regarding setting up PCAdmin to establish connection between the SBX system and PCAdmin. Remember, when connecting to the SBX IP using a LAN switch, a straight-through patch cable (not a crossover cable) is required.

Configuring The VoIP Card Using PCAdmin

NOTE: Digital phone-based programming is shown on [page 5-22](#).

1. Double-click Pre-programmed > Configuration

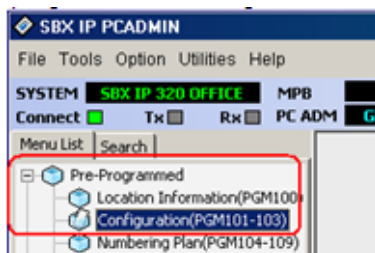

- Right-click on the VoIB, then select Logical Assignment.

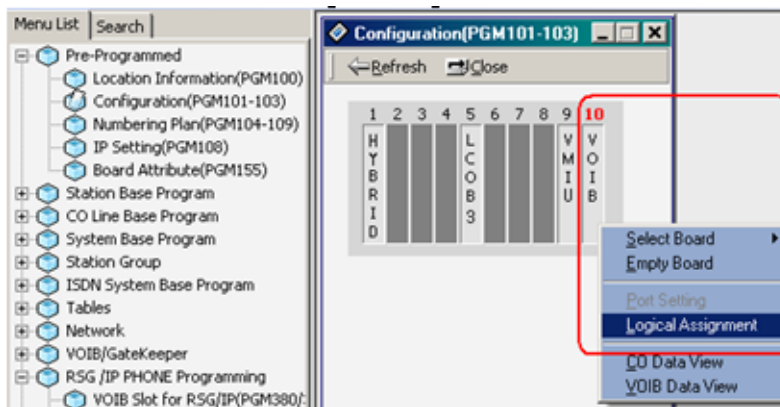

- In Logical Assignments, right-click VoIB and Select (Virtual VoIB) => Append to Station. A notation of 99 will be entered in the STA Board field.

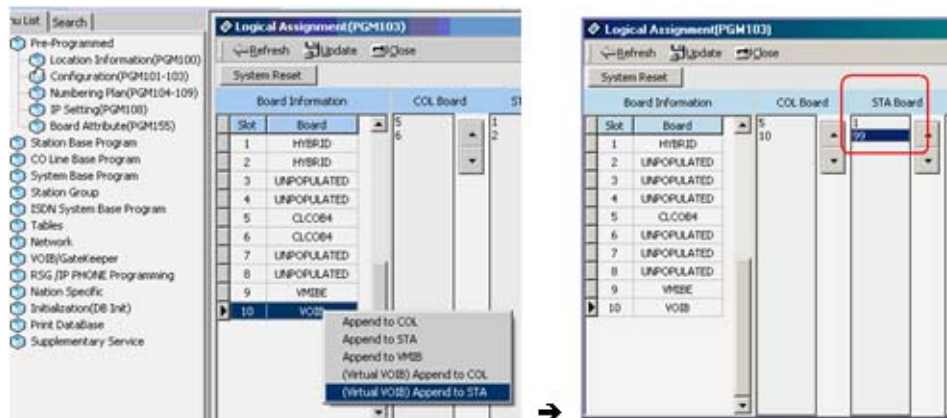

- Click **Update**.
- In VoIB Gateway > VoIB Gatekeeper Settings enter the IP Address, Default Gateway, and Subnet Mask that you are assigning to the VoIP card per the worksheet.

- Click Update.

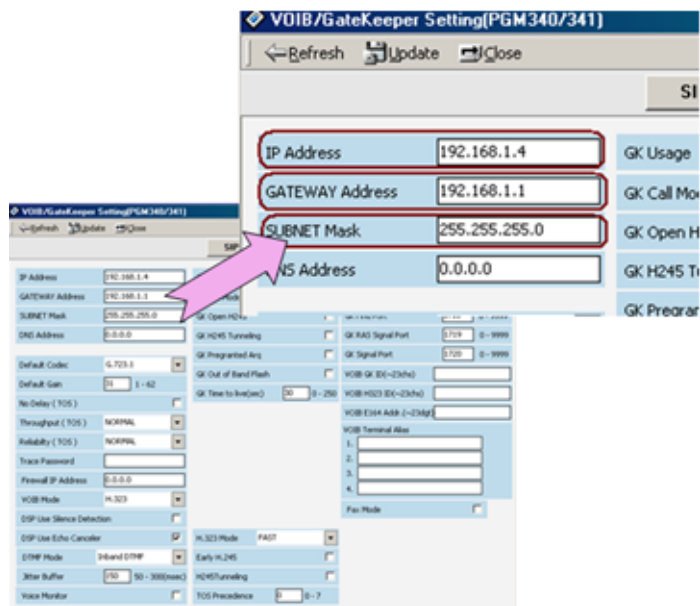

- In RSG IP Programming, double-click VoIB Slot for RSG/IP.

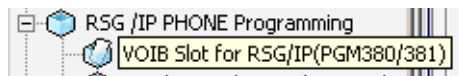

- Select the VoIB card (10), then click the > button to move the selection to the right-hand column.

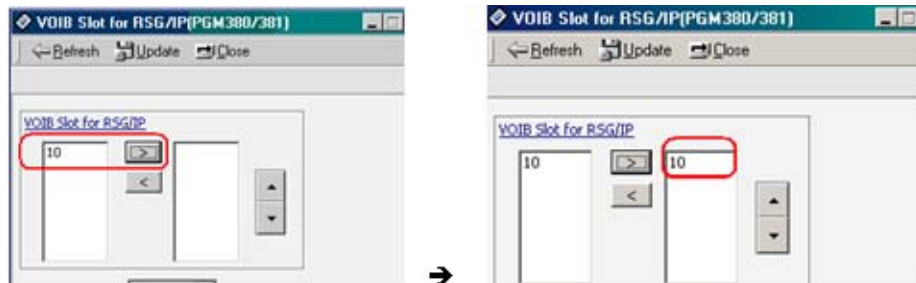

You will see the card slot on the right side.

9. Click Update.

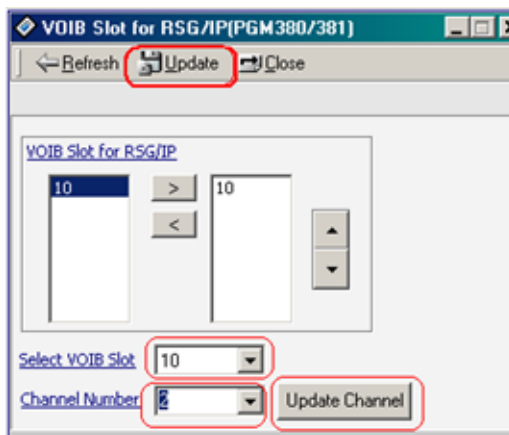

10. Select the card from the VoIB Slot dropdown.
11. Select 2 for the number of channels to be used for IP Phones from the Channel Number dropdown.
12. Click Update Channel.
13. Select the 2 from the IP Phone Number dropdown, then click Update Num.

This tells the system to assign 2 IP stations.

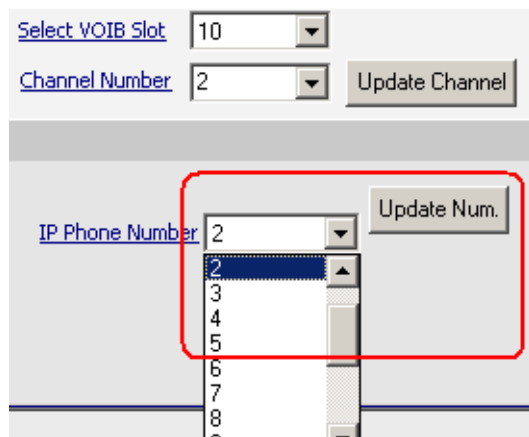

14. Click Update.

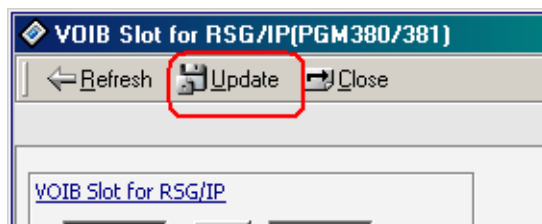

15. Reset the KSU Double-click RSG/IP Programming > IP Phone Attributes.

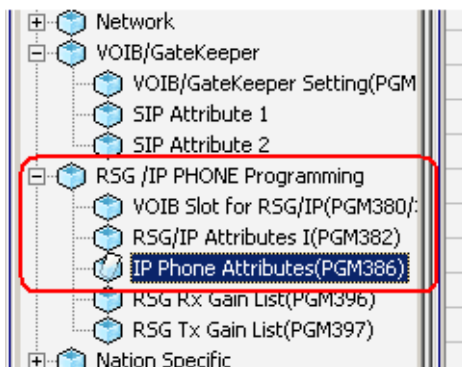

16. Double-click on bin 1 (row 1).

- Enter the MAC address which you will find labeled on the bottom of the IP phone, then click Update.

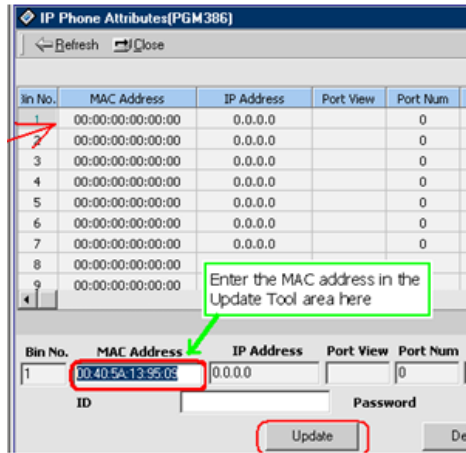

Result:

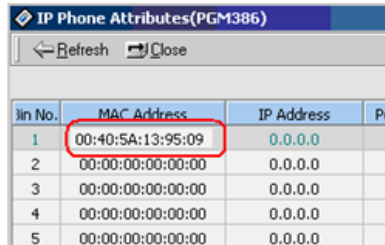

NOTE: Be sure to include the colons in the MAC address.

You do not need to program the other data values in PGM 386 for IP7000 remote phones. The ID and Password values will be used when you are configuring a Nomad SP (Soft Phone).

Configuring IP phone settings

To verify connectivity to the VoIP card, you should ping the VoIP card from where the phone is located.

Setting up the IP Phone will vary depending upon the network infrastructure, IP Address schema, and location of the system. You need the following information to properly configure the IP Phone:

- The IP Address of the VoIP card.
- Whether the IP Address information is supplied dynamically (DHCP) or statically
- An IP Address and Subnet Mask for the IP Phone (either static or DHCP).
- The Default Gateway IP Address (either static or DHCP).

NOTE: If IP Addresses are static, you will need to obtain the correct IP Address, Subnet Mask, and Default Gateway information from the IT Administrator.

Connect the IP Phone to the local network. It can be powered with an AC power adapter or a port on a POE (Power Over Ethernet) switch. The power adaptor is part #6899-PS. When powered, the IP Phone completes its boot sequence, then attempts to connect to the VoIP Card. If the phone is unable to connect to the VoIP card, the following message is displayed:

NO RESPONSE FROM MFIM

SET [*] - RESTART [#]

1. Press * to begin configuring the phone.
2. Use the Volume + and - to navigate the settings.
3. Enter information as follows:
 - If you are prompted for a password: Dial 147*
 - At MODE[R/L] ? (This is the Remote/Local Setting). All IP Phones are considered remote to the SBX IP no matter where they are physically or logically. Set the mode to REMOTE. Press # until the display shows:

MODE[R/L] ?

[REMOTE] - CHANGE[#]

4. Press Hold/Save to store the setting as REMOTE.
5. Press the Volume + until DHCP ? appears.

NOTE: If IP Addressing is assigned via DHCP, this should be **enabled**.
If IP Addressing is Static, this should be **disabled**.

6. Press # until the display shows the correct state.
7. Press Hold/Save to retain the entry.
8. Press the Volume + until MFIM IP ADDRESS (DOT:*) appears. This is the VoIB IP Address Field. MFIM = VoIB. Enter the IP Address on the dial pad. Press the * to enter a "." (dot). For example, to enter 192.168.1.10, dial 192*168*1*10. Press Hold/Save to retain the entry.

MFIM IP ADDRESS(DOT:*)

xxx.xxx.xxx.xxx (The VoIB IP Address)

9. Press the Volume + until ROUTER IP ADDRESS(DOT:*) appears. This is the Default Gateway IP Address Field. If IP Addressing is being assigned, you won't need to program this field. If IP Addressing is statically assigned, enter the IP Address of the Default Gateway and press Hold/Save.

ROUTER IP ADDRESS(DOT:*)

xxx.xxx.xxx.xxx (Default Gateway IP Address)

10. Press the Volume + until PHONE NET MASK(DOT:*) appears. This is the Subnet Mask associated with the IP Address of the phone. If IP Addressing is being dynamically assigned, you won't need to program this field. If IP Addressing is statically assigned, enter the IP Address of the Default Gateway and press Hold/Save.

PHONE NET MASK(DOT:*)

xxx.xxx.xxx.xxx (Subnet Mask)

11. Press the Volume + until PHONE IP ADDRESS(DOT:*) appears. This is the station IP Address Field. If IP Addressing is being dynamically assigned, you won't need to program this field. If IP Addressing is statically assigned, enter the IP Address of the station and press Hold/Save.

PHONE IP ASSIGNED(DOT:*)

xxx.xxx.xxx.xxx (Station IP Address)

12. When these fields have been completed, press the Speaker button to reboot the IP Phone. The phone will contact the VoIP card and register to the system. It receives its station number assignment from the KSU.

In this example, the IP address and station number information appears after two IP phones have registered to the system:

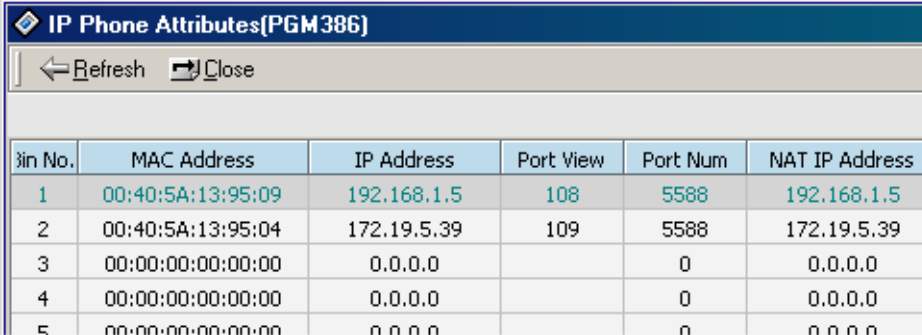

| Line No. | MAC Address | IP Address | Port View | Port Num | NAT IP Address |
|----------|-------------------|-------------|-----------|----------|----------------|
| 1 | 00:40:5A:13:95:09 | 192.168.1.5 | 108 | 5588 | 192.168.1.5 |
| 2 | 00:40:5A:13:95:04 | 172.19.5.39 | 109 | 5588 | 172.19.5.39 |
| 3 | 00:00:00:00:00:00 | 0.0.0.0 | | 0 | 0.0.0.0 |
| 4 | 00:00:00:00:00:00 | 0.0.0.0 | | 0 | 0.0.0.0 |
| 5 | 00:00:00:00:00:00 | 0.0.0.0 | | 0 | 0.0.0.0 |

13. Test the IP phone by dialing an extension number.

Programming VoIP card settings from a digital station

This is an alternative to PAdmin programming (shown in the preceding section). Disregard this section if you have configured the IP phone using PAdmin.

1. Enter KSU programming from the digital attendant phone.
2. Press PGM.
3. Dial 103 (Logical Slot Assign).
4. Press Flex Button 2 (STA).
5. What to enter will depend on what cards are installed. If there are two 3x8 Expansion cards installed the display will show 01 02
Dial 01 02 99 to assign station ports to the VoIB.
6. Click Save.

Assign IP Address to the VoIB

1. Press PGM.
2. Dial 340 (VoIB Attributes).
3. Press Flex Button 1 (IP ADDR).
4. Dial the IP Address (e.g., 192.168.1.10 Dial 192168010010).
5. Click Save.
6. Press Flex Button 2 (Gateway ADDR) - Mandatory.
7. Dial the default Gateway for the VoIB (ex: for 192.168.1.1 dial 192168001001).
8. Click Save.
9. Press Flex Button 3 (Subnet Mask).
10. Dial the Subnet Mask (ex: for 255.255.255.0 dial 255255255000).
11. Click Save.

VoIB Slot/Port Usage Assignment

1. Press PGM.
2. Dial 380 (VoIB Slot Assignment).
3. Press Flex Button (VoIB Slot).
4. Dial 10 (Slot Number to Program).
5. Click Save.
6. Press Flex button 2 (RSG/IP channel Assign).
7. Dial 10 (Slot Number).
8. Dial 4 (or number of channels to reserve for IP Phones).
9. Click Save.

VoIB IP Station Assignment

1. Press PGM.
2. Dial 381 (RSG/IP No Assign).
3. Press Flex Button 2.
4. Dial the number of IP stations you wish to program (e.g., 04).
5. Click Save.
6. Reset the system and VoIP card.

Program IP Phone Attributes - The number of bins available to program will correspond to the number of IP phones programmed in PGM 381.

1. Press PGM.
2. Dial 386 (IP Phone Attrib).
3. Dial the Bin Number (for example, 01 This would be the first IP station).
4. Press Flex Button 1.
5. Dial the MAC Address of the IP Phone.

NOTE: * = A, # = B, NAV Left = C, NAV Right = D, NAV Up = E, NAV Down = F

6. Click Save.

Starting the SBX IP System

Before Starting the SBX IP System

In preparation for programming, perform the following steps:

1. Turn the DIP switch (SW2) ON prior to installing the MBU, to protect the system data in case of power failure.
2. Check that the DIP switch (SW1) of the MBU is set to All ON.
3. Plug the AC power cord into the SBX IP system and AC outlet.
4. Program the Nation Code (PGM 100) as applicable.
5. Reset the SBX IP system.
6. Set the 4th pole (SW1) of the MBU to OFF when the system operates normally, to protect programmed features after system power-up and initialization.

Basic Programming

The SBX IP system can be programmed to meet individual needs. There are two ways to perform Admin Programming:

- PC Admin - Refer to the PC Admin Programming Manual.
- DKT - In this manual, DKT (Station 100) Admin Programming is described.

DKT Programming

All programming is done at one station (Station 100, Station Port #00, by default) using the 7224D Digital Key Telephone.

Additional programming stations may be assigned (PGM 113 - FLEX 1), but only one DKT can be active in the programming mode at any one time.

NOTE: All programming must be performed from a 24-button phone or the PCAdmin software program.

When in programming mode, Station 100 does not operate as a normal telephone, but instead works as a programming instrument with all the buttons redefined as follows:

- Dial Pad Keys - used to enter numerical information in the various data fields.
- Flexible Buttons (the 24 buttons located on the right side of the phone) - used to indicate a specific data field and to enter information.
- Soft Buttons (BACK / DELETE / SAVE) - used to go back / delete data / save data input.

Button Explanation

The following graphic and its associated table describe the buttons and function keys. (Refer to the IP7208D/IP7024D User Guide for detailed information and operation instructions.)

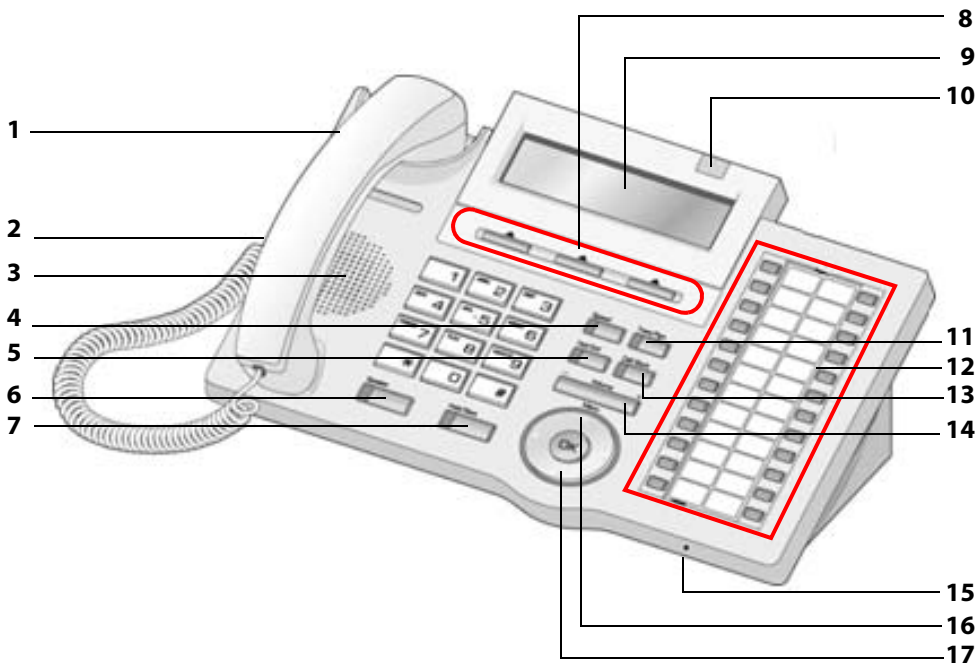

| IP7224D Keypad - Basic Features | | |
|--|----------------|--|
| 1 | Handset | Used for handset call. |
| 2 | Headphone | When using a headphone, toggles the headphone state. |
| 3 | Speaker | When in speaker mode, used to listen to a caller in a handsfree mode. |
| 4 | Speed | Used to access speed dialing, save number redial, and last number redial. The button is also used to access flexible button programming. |
| 5 | DND | The Do Not Disturb feature lets you activate a “do not ring this phone” mode. When DND is active, this button is red. |
| 6 | Speaker Button | Toggles speakerphone state between speaker mode and handset mode. The button is red when speakerphone is active. |
| 7 | Hold/Save | Puts a call on hold or saves the PGM. |
| 8 | 3 Soft Buttons | Used to work in conjunction with fixed and flexible features. |
| 9 | LCD Display | Displays phone status information, dialing directories, and test message information. |
| 10 | Ring LED | Illuminates when the phone is ringing. |
| 11 | Trans/PGM | Used to set up a conference call or transfer a call. |
| 12 | Flexible | The remaining XX Flex buttons can be assigned a feature. |
| 13 | Call back | A station can initiate a call back request to another busy station. Once that station becomes idle, the station that left the call back request is signaled. |
| 14 | Volume | Adjusts the audio level. |
| 15 | MIC | When in speaker mode, used to speak to a caller in a handsfree mode. |
| 16 | Menu | Used to move to the desired option (Dial, MSG, Program) and for arrows key. |
| 17 | Phone Book | Use to save a phone number and to make calls with saved information. |

Entering the Programming Mode

To enter programming mode, perform the following steps:

1. Lift the handset or press the speaker button on the Admin station. ICM dial tone will sound.
2. Press the [TRANS/PGM] button and dial *#. A confirmation tone will sound.
3. Enter the Admin password, if a password has been set; a confirmation tone sounds indicating that the station is in Admin Programming mode.
4. Access each program by pressing the [TRANS/PGM] button. The following will initially display:

ENTER PGM NUMBER

5. Dial the desired three-digit program number. If an error is made while entering data, the [TRANS/PGM] button will return to the previous status.

NOTE: To return to the previous state while in Admin Programming, press the [BACK] soft button (this clears the temporary data fields).

Permanent Update Procedure

To accept changes while programming, perform the following steps:

1. Press the [HOLD/SAVE] button when all changes have been entered to store the data permanently.
2. If all data was entered correctly, a confirmation tone will sound when pressing the [HOLD/SAVE] button. If there were any errors in the entering of data, an error tone will sound and data will not be stored in the permanent memory.

Resetting the System

To reset the system, perform the following:

Enter [PGM] + 450, then [FLEX] +15, then press the [HOLD/SAVE] button.

Pre-Programming

Location PGM - Nation Code and Site Name (PGM 100)

NOTE: To modify Nation Code, the 4th pole of the DIP switch (SW1) on the MBU must be turned ON.

NOTE: SBX IP supports only English language and prompts.

Nation Code

To program the Nation Code, perform the following steps:

1. Press the [TRANS/PGM] button + PGM number (100), then [FLEX1] + 1 [Nation Code for United States].
2. Press the [HOLD/SAVE] button to accept the change.
3. Reset the SBX IP to initialize the Database for Nation.
4. Set the 4th pole (SW1) of the MBU OFF, to protect programmed features.

Site Name

1. Press the [TRANS/PGM] button + Enter Site Name (use the following DKT Map, Max. 23 characters allowed), then press [FLEX 2].
2. Press the [HOLD/SAVE] button to accept the change.

| | | |
|------------|--------|--------|
| . - 13 | A - 21 | D - 31 |
| Q - 11 | B - 22 | E - 32 |
| Z - 12 | C - 23 | F - 33 |
| 1 - 10 | 2 - 20 | 3 - 30 |
| G - 41 | J - 51 | M - 61 |
| H - 42 | K - 52 | N - 62 |
| I - 43 | L - 53 | O - 63 |
| 4 - 40 | 5 - 50 | 6 - 60 |
| P - 71 | T - 81 | W - 91 |
| Q - 72 | U - 82 | X - 92 |
| R - 73 | V - 83 | Y - 93 |
| S - 74 | 8 - 80 | Z - 94 |
| 7 - 70 | | 9 - 90 |
| Blank - *1 | | |
| : - *2 | 0 - 00 | |
| , - *3 | | |

NATION CODE TABLE

| Nation | Code |
|----------------|-------------|
| Argentina | 54 |
| Australia | 61 |
| Bahrain | 973 |
| Bangladesh | 880 |
| Belgium | 32 |
| Bolivia | 591 |
| Brazil | 55 |
| Brunei | 673 |
| Burma | 95 |
| Cameroon | 237 |
| Canada + USA | 1 |
| Chile | 56 |
| China (Taiwan) | 886 |
| CIS | 7 |
| Columbia | 57 |
| Costa Rica | 506 |
| Cyprus | 357 |
| Czech | 42 |
| Denmark | 45 |
| Ecuador | 593 |
| Egypt | 20 |
| El Salvador | 503 |
| Ethiopia | 251 |
| Fiji | 679 |
| Finland | 358 |
| France | 33 |
| Gabon | 241 |
| Germany | 49 |
| Ghana | 233 |

| Nation | Code |
|---------------|-------------|
| Greece | 30 |
| Guam | 671 |
| Guatemala | 502 |
| Guyana | 592 |
| Haiti | 509 |
| Honduras | 504 |
| Hong Kong | 852 |
| India | 91 |
| Indonesia | 62 |
| Iran | 98 |
| Iraq | 964 |
| Ireland | 353 |
| Israel | 972 |
| Italy | 39 |
| Japan | 81 |
| Jordan | 962 |
| Kenya | 254 |
| Korea | 82 |
| Kuwait | 965 |
| Liberia | 231 |
| Libya | 218 |
| Luxembourg | 352 |
| Malaysia | 60 |
| Malta | 356 |
| Mexico | 52 |
| Monaco | 377 |
| Morocco | 212 |
| Netherlands | 31 |
| New Zealand | 64 |

| Nation | Code |
|----------------|-------------|
| Nigeria | 234 |
| Norway | 47 |
| Oman | 968 |
| P.N.G. | 675 |
| Pakistan | 92 |
| Panama | 507 |
| Paraguay | 595 |
| Peru | 51 |
| Philippines | 63 |
| Portugal | 351 |
| Qatar | 974 |
| Saudi Arabia | 966 |
| Senegal | 221 |
| Singapore | 65 |
| South Africa | 27 |
| Spain | 34 |
| Sri Lanka | 94 |
| Swaziland | 268 |
| Sweden | 46 |
| Switzerland | 41 |
| Thailand | 66 |
| Tunisia | 216 |
| Turkey | 90 |
| U.A.E. | 971 |
| United Kingdom | 44 |
| United States | 1 |
| Uruguay | 598 |
| Venezuela | 58 |
| Y.A.R. | 967 |

Board Assignment (PGM 101)

To use a CO line, an extension line, and a board, ensure that the code of these boards are registered on the system at PGM 101.

When registering a board, if the fourth pole of switch bank one (SW1) of the MBU is ON, the board is automatically registered into the system database.

After registering a new board to the system, place the fourth pole of (SW1) in the OFF position and perform a system reset.

While in the Admin programming mode:

1. Press the [TRANS/PGM] button + PGM number (101).
2. Enter slot number (2 digits).
3. Press [FLEX1] button.
4. Enter Board Type code (2 digits).
5. Press the [HOLD/SAVE] button to accept the change.

Table 6-1 Board ID

| STA | CODE | COL | CODE | ETC | CODE |
|--------|------|------|------|------|------|
| HYBRID | 17 | VoIB | 41 | VMIB | 64 |

Table 6-2 Slot Definition

| SLOT NUMBER | SLOT POSITION | KINDS OF BOARDS |
|-------------|----------------------------------|-----------------|
| 01 | Hybrid on BKSU | HYBRID |
| 02 | Optional extension board on BKSU | HYBRID |
| 03 | Hybrid port on EKSU | HYBRID |
| 04 | Optional extension board on EKSU | HYBRID |
| 05 | LCOB on BKSU | -- |
| 06 | T1 / PRI | -- |
| 07 | LCOB on EKSU | -- |
| 08 | Optional LCOB on EKSU | -- |
| 09 | VMIB on BKSU | VMIB |
| 10 | VoIB on BKSU | VoIB |

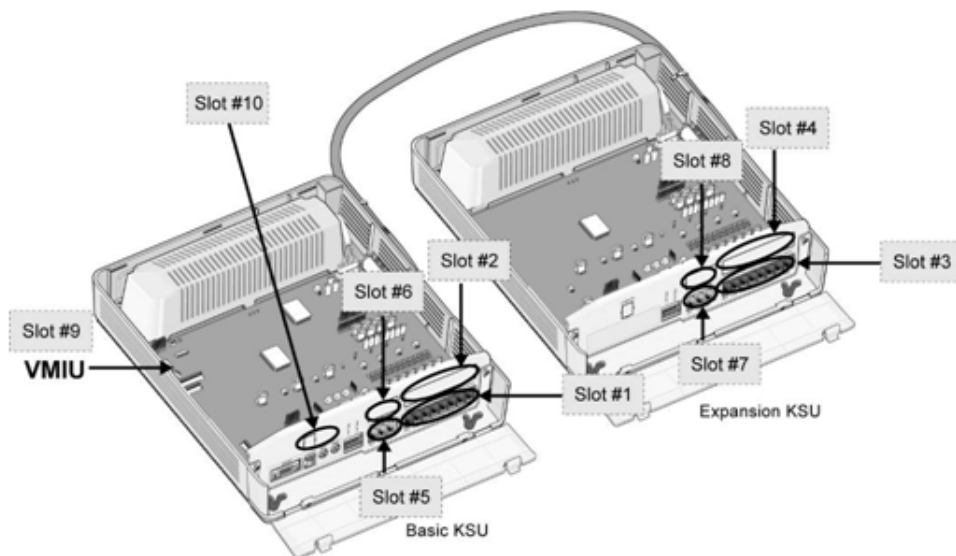

Figure 6-1 Slot Locations

Logical Slot Assignment (PGM 103)

If the assignment of each board is at the end, it is automatically registered by slot number order. You can reassign the slot order of each CO Line or extension line as appropriate to your circumstance.

COL Board

1. Press the [TRANS/PGM] button + PGM number (103).
2. Press [FLEX1] button.
3. Enter logical slot number (CO board slot: 05, 06, 07, 08, 10).
4. Press [HOLD/SAVE] button to accept change.

STA Board

1. Press the [TRANS/PGM] button + PGM number (103).
2. Press the [FLEX 2] button.
3. Enter logical slot number (STA board slot: 01-04).
4. Press the [HOLD/SAVE] button to accept the change.

VMIB Board

1. Press the [TRANS/PGM] button + PGM number (103).
2. Press the [FLEX 3] button.
3. Enter logical slot number (VMIB Slot: 09).
4. Press the [HOLD/SAVE] button to accept the change.

Numbering Plan Type (PGM 104)

To program the Numbering Plan Type, perform the following:

1. Press the [TRANS/PGM] button + 104.
2. Enter the Numbering Plan Type (1 digit, refer to the following table).
3. Press the [HOLD/SAVE] button to accept changes.

Table 6-3 Slot Definition

| NUMBER SET TYPE/ PRESS # | INTERCOM RANGE | DEFAULT | REMARK |
|-----------------------------|----------------|---------|--|
| 01 | 100-147 | Yes | As the basic type, the 1st digit of the station number should be 1-4 |
| 02 | 100-147 | No | The station number can be changed up to 799 |
| 03 | 100-147 | No | |
| 04 | 700-747 | No | |
| 05 | 200-247 | No | |
| 06 | 21-68 | No | |
| 07 | 100-147 | No | |
| 08 | 100-147 | No | The station number can be changed up to 999 |

Flexible Numbering Plan (PGM 105)

To set the Flexible Numbering Plan, perform the following steps:

1. Press the [TRANS/PGM] button + 105.
2. Enter the station range (dial the Start and End numbers as described in the table).
3. Press the [HOLD/SAVE] button to accept the changes.

Table 6-4 Numbering Plan Detail

| STATION NUMBERS | | | | DESCRIPTION |
|-----------------|------------|------------|------------|--|
| 000 100 | 001 101 | 002 102 | 003 103 | [TRANS/PGM] + 105 |
| 000 100 | 001 101 | 002 102 | 003 103 | <p>Station Number Assign-Four station numbers correspond to the four (4) port numbers. The station number length is in the range of two (2) digits through four (4) digits. There are two methods for changing the station number:</p> <p>Dial two station numbers - Dial the range of the start and end station numbers. The LCD will show the dialed range value. Press the [HOLD/SAVE] button to accept the change. All LEDs of BTNs will be extinguished.</p> <p>Press one of FLEX 1-4 - Each FLEX button (1-4) is assigned to a corresponding station number (1- 4) on the current LCD. The LED of the pressed Flexible button will show steady light. Dial the new station number and press the [HOLD/SAVE] button to accept change, or press another Flexible button to assign a station number to other stations without saving.</p> <p>To change the next four (4) station numbers then press [▼] button. If you want to change previous four (4) station numbers, then press [▲] button.</p> <p>To delete all station numbers, press the [SPEED] button and press the [HOLD/SAVE] button; all station numbers will be cleared.</p> |
| 000 100 | 001 400 | 002 102 | 003 103 | Press the [HOLD/SAVE] button to save changes to the database permanently (Ex: Press FLEX 2, dial 400 and press [HOLD/SAVE] button). |

Flexible Numbering Plan (PGM 106-107, & 109)

To program Flexible Numbering using PGM 106, perform the following steps:

1. Press the [TRANS/PGM] button + 106.
2. Enter the desired code (refer to the following table).
3. Press the [HOLD/SAVE] button to accept changes.

Table 6-5 Flexible Numbering Plan (PGM 106)

| FLEX | ITEM | DEFAULT VALUE |
|------|--|---------------|
| 1 | Station Group Pilot Number Range | 620-629 |
| 2 | Internal Page Zone Number Range | 501-510 |
| 3 | Internal All Call Page | 543 |
| 4 | Meet Me Page | 544 |
| 5 | External Page Zone | 545 |
| 6 | All Call Page (Internal/External) | 549 |
| 7 | SMDR Account Code | 550 |
| 8 | Flash Command to CO Line | 551 |
| 9 | Last Number Redial (LNR) | 552 |
| 10 | Do-Not-Disturb | 553 |
| 11 | Call Forward | 554 |
| 12 | Speed Dial Program | 555 |
| 13 | MSG Wait/Call-Back Enable | 556 |
| 14 | MSG Wait/Call Back Answer | 557 |
| 15 | Speed Dial Access | 558 |
| 16 | Cancel DND/CFW/Pre-Selected MSG Features | 559 |
| 17 | SLT Hold | 560 |
| 18 | Reserved | N/A |
| 19 | Reserved | N/A |
| 20 | SLT Program Mode Select | 563 |
| 21 | ACD Reroute | 564 |

To program Flexible numbering using PGM 107, perform the following steps:

1. Press the [TRANS/PGM] button + 107.
2. Enter the desired code (refer to the following table).
3. Press the [HOLD/SAVE] button to accept the changes.

Table 6-6 Flexible Numbering Plan (PGM 107)

| FLEX | ITEM | DEFAULT VALUE |
|------|--|---------------------------------------|
| 1 | Alarm Reset | 565 |
| 2 | Group Call Pickup | 566 |
| 3 | UCD Group DND | 568 |
| 4 | Night Answer | 569 |
| 5 | Call Park Location Range | 601-610 |
| 6 | Direct Call Pick-Up | 7 |
| 7 | Access CO Line Group | 801-824 (8 + CO Group Line Number) |
| 8 | Access Individual CO Line | 88 (88 + CO Line Number) |
| 9 | Reserved | N/A |
| 10 | Access Held CO Line Group | 8* |
| 11 | Access Held Individual CO Line | 8# (8# + CO Line Number) |
| 12 | Access to CO Line in the 1st Available CO Line Group | 9 |
| 13 | Attendant Call | 0 |
| 14 | Door Open - 1 | #*1 |
| 15 | Door Open - 2 | #*2 |
| 16 | Door Open - 3 | #*3 |
| 17 | Door Open - 4 | #*4 |
| 18 | VM MSG Wait Enable | *8 |
| 19 | VM MSG Wait Cancel | *9 |

To program Flexible numbering using PGM 109, perform the following steps:

1. Press the [TRANS/PGM] button + 109.
2. Enter the desired code (refer to Table).
3. Press the [HOLD/SAVE] button to accept changes.

Table 6-7 Flexible Numbering Plan (PGM 109)

| FLEX | ITEM | DEFAULT VALUE |
|------|--------------------------------------|---------------|
| 1 | Reserved | n/a |
| 2 | Reserved | n/a |
| 3 | Reserved | n/a |
| 4 | Conference Room | 57 |
| 5 | SLT Conference Page Join | 58 |
| 6 | Unsupervised Conf Timer Extend | ## |
| 7 | Remote Mobile Extension (MEX) Number | #1 |

System IP Setup (PGM 108)

To set up IP functionality, perform the following. Use the # key to skip to the next menu item, as needed.

IP Name

1. Press the [TRANS/PGM] button + 108.
2. Press the FLEX 1 button.
3. Enter the desired IP Name (up to 15 characters).

| | | | | | | | | | | | | | | | |
|---|------------------------------|----------------------|------------------------------|----------------------|----------------------|----------------------|------------------------------|----------------------|------------------------------|---|-----------|---|--------------------|--|--|
| <table border="1"> <tbody> <tr> <td>1</td> <td>A-21 B-22 C-23</td> <td>D-31 E-32 F-33</td> </tr> <tr> <td>G-41 H-42 I-43</td> <td>J-51 K-52 L-53</td> <td>M-61 N-62 O-63</td> </tr> <tr> <td>P-71 Q-72 R-73 S-74</td> <td>T-81 U-82 V-83</td> <td>W-91 X-92 Y-93 Z-9#</td> </tr> <tr> <td>*</td> <td>OPER 0</td> <td>#</td> </tr> </tbody> </table> | 1 | A-21 B-22 C-23 | D-31 E-32 F-33 | G-41 H-42 I-43 | J-51 K-52 L-53 | M-61 N-62 O-63 | P-71 Q-72 R-73 S-74 | T-81 U-82 V-83 | W-91 X-92 Y-93 Z-9# | * | OPER 0 | # | Other Codes | | |
| | 1 | A-21 B-22 C-23 | D-31 E-32 F-33 | | | | | | | | | | | | |
| | G-41 H-42 I-43 | J-51 K-52 L-53 | M-61 N-62 O-63 | | | | | | | | | | | | |
| | P-71 Q-72 R-73 S-74 | T-81 U-82 V-83 | W-91 X-92 Y-93 Z-9# | | | | | | | | | | | | |
| | * | OPER 0 | # | | | | | | | | | | | | |
| 1 = 10 | 6 = 60 | Space = *1 | | | | | | | | | | | | | |
| 2 = 20 | 7 = 70 | , = *3 | | | | | | | | | | | | | |
| 3 = 30 | 8 = 80 | : = *2 | | | | | | | | | | | | | |
| 4 = 40 | 9 = 90 | . = 13 | | | | | | | | | | | | | |
| 5 = 50 | 0 = 00 | * = 0* | | | | | | | | | | | | | |

4. Press the [HOLD/SAVE] button to accept the changes.

Server IP Address

1. Press the [TRANS/PGM] button + 108.
2. Press the FLEX 2 button.
3. Enter the server IP Address (12 digits). (for example, 192168131154 for 192.168.131.154)
4. Press the [HOLD/SAVE] button to accept changes.

CLI IP Address

1. Press the [TRANS/PGM] button + 108.
2. Press the FLEX 3 Button.
3. Enter the CLI IP Address (12 digits).
4. Press the [HOLD/SAVE] button to accept the changes.

Gateway Address

1. Press the [TRANS/PGM] button + 108.
2. Press the FLEX4 button.
3. Enter the Gateway Address (12 digits).
4. Press the [HOLD/SAVE] button to accept changes.

Subnet Mask Address

1. Press the [TRANS/PGM] button + 108.
2. Press the FLEX5 button.
3. Enter the Subnet Mask (12 digits).
4. Press the [HOLD/SAVE] button to accept changes.

BLF Manager

BLF Manager is an optional Windows software program that can be used to manage Busy Lamp Field (BLF) updates for systems networked over VoIP.

BLF Manager must be installed to one system in the SBX IP network and must be reachable over IP by all SBX KSUs.

BLF Manager software is not required for VoIP networking. It is only necessary if DSS/BLF updates on stations and DSS console are desired.

There is no need for BLF Manager software unless you have networked systems.

BLF Manager Installation

Requirements

OS: Windows 95 or above

CPU: Pentium 500Mhz or above

Memory: 128M or more (256M recommended)

HDD: More than 30MB of free space

Installation

Make a directory and copy "BLFManager.exe" to it.

Automatic running

To run BLF Manager automatically, put a shortcut link to BLFManager.exe into "Startup programs".

Uninstallation

To remove BLF Manager from the server PC, delete the installation directory.

BLF Manager in detail

BLF Manager screen

The following window is what you see when BLF Manager is running:

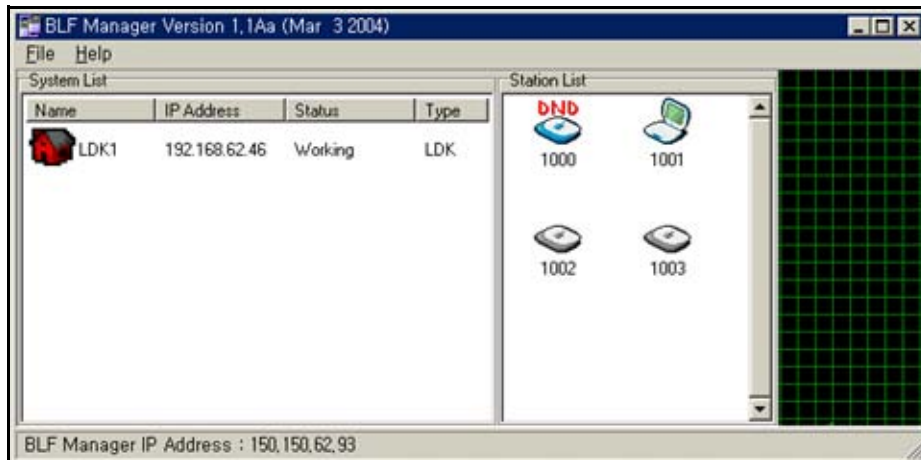







System list window (Status of systems)

- Name - Shows the name of system (PGM 100 - FLEX 2, Site Name).
- IP Address - Shows the IP address of system.
- Status - Shows the status of system.

| Status | Description |
|----------|---|
| Working | Communication with the system works well. |
| No Data2 | There is no data from the system for over 90 seconds. |
| Error | There is a communication error with the system. |

Station list window (Extension status)

This window shows an extension status of selected system.

| Icon | Status |
|---|--|
|  | Status is idle |
|  | Station is busy |
|  | Station is in DND |
|  | Station leaves a MSG-Wait |
|  | Station is disconnected from the system |
|  | BLF Manager isn't receiving a station status |

Network traffic window



This graph shows the status of network traffic between the BLF Manager and each of the systems. It is located on the right side of the BLF Manager window.

File menu

- File->Initialize
Initialize all information of BLF Manager. Delete all system & station information.
CAUTION: Only perform initialization if prepared to re-program BLF Manager.
- File->Exit
Exit BLF Manager.

Using Database Upload/Download

PC Admin is used to upload/download SBX IP MBU Database from/to a PC file. Three connection types are available (TCP, Serial, or Modem). It is up to you which method to use. These three methods differ slightly by configuration, transfer speed, and transferring protocol.

NOTE: It is strongly recommended that after you upload any type of database, that you reset the SBX IP system.

PC Requirement

- PC OS: Windows 2000 or later
- PC Memory: minimum of 128 MB
- PC Free Disk Space: 10MB or higher (larger than 20 MB recommended)
- PC Monitor Resolution: VGA or higher
- PC Modem: General analog dial-up modem (only for upgrading through an analog phone line)

Connection Method with SBX IP

To use the database Up/Down SBX IP software needed to transfer system data, you will need to select one of the following connection methods:

Serial Connection

SBX IP MBU software can be updated through RS-232C interface in a PC.

TCP Connection

SBX IP MBU software can be updated through LAN interface at the remote PC.

Modem Connection

SBX IP MBU software can be updated through MODEM interface at the remote PC.

Installation

Database Up/Down SBX IP is found in PC Admin for SBX IP. Refer to the SBX IP PC Admin Guide.

NOTE: In the setup procedure, if the PC is Windows 95 generic or some system DLL Files need updating, the setup program will request that the PC be restarted.

Main software components

If you successfully install SBX PC Admin, and use a default installation, the following files will reside in the "execution" directory (see Note below):

- PC Admin.exe: Main Execution File
- UpLDK.exe: Software Upgrade Tool
- DBUDLDK.exe: D/B Upload/Download
- LDKDiag.exe: Remote Diagnostics

NOTE: For default installations, the Execution Directory is located in this folder:
Program Files\Vertical Communications Inc\SBX PCADMIN\Admin folder.

Choosing Up/Download and Connection Type

Upload To SBX IP: uploads the database file in the PC to the SBX IP system.

Download the SBX IP: downloads the MPB database from the SBX IP to the PC.

1. Select the system to which connection is being made.
2. Select correct upload/download option.
3. Select appropriate connection method (see [page 7-1](#)).

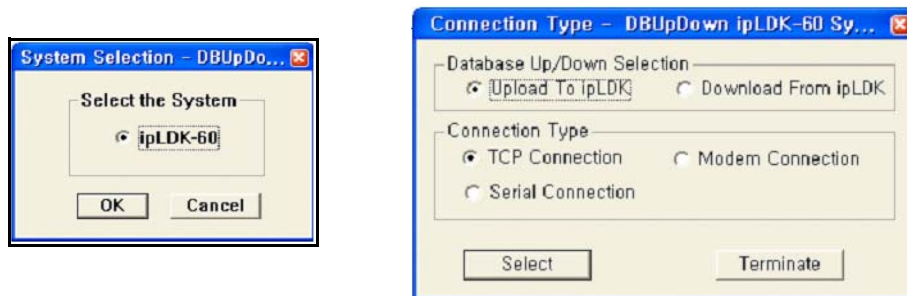

User Information Dialog

After selecting the desired upload/download and connection types, there are several configuration requirements that need to be set: including Admin Password, Database File (*.usr), etc. in the “User Information Dialog”. These differ according to the selected connection type.

Up/Download by Serial Connection

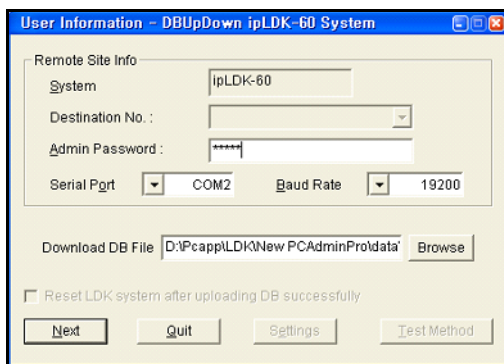

NOTE:

It is strongly recommended that you reset the system after uploading any DB.

The transferring baud rates of the PC and the COM port in the SBX IP system must be identical. SBX IP system baud rate can be changed in PGM 174.

If you set the transferring baud rate of the PC and SBX IP system to 57600 bps, some stations display incorrect characters in their LCD, or the SBX IP system may be unstable. Although 57600bps is the fastest for upgrading, slower rates (19200bps and 9600bps) are available in case there are problems (as previously described) using the faster rate.

1. Enter the following entries for Serial connection:
 - *Serial Port* -- Serial port No. in PC connected to SBX IP COM port.
 - *Baud Rate* -- Choose the transferring baud rate (see Note below).
 - *Admin Password* -- If a password is needed to upload/download MBU s/w DB.
 - *Database File* -- The database file to be uploaded/downloaded.
 - *Check Button* -- Resets the system after successfully uploading the database.
2. Press the [Next] button.

Up/Download by TCP Connection

NOTE: Assign the SBX IP system IP address before you attempt TCP connection. You can program the SBX IP system IP address in PGM 108.

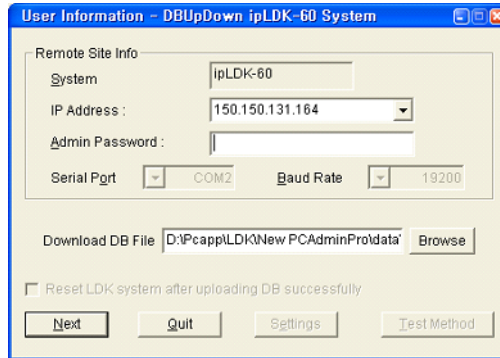

1. Enter the following for TCP connection:
 - *IP Address* -- IP address of the destination SBX IP system (see note).
 - *Admin Password* -- If the SBX IP requires a password to upload/download MBU software database.
 - *Database File* -- The database file to be uploaded/downloaded.
 - *Check Button* -- Resets the SBX IP system after uploading database successfully. It is strongly recommended that you reset the SBX IP system after uploading any type of database.
2. Press the [Next] button to go to the next step.

Up/Download by MODEM Connection

NOTE: Before attempting a modem connection, assign the analog telephone number of the SBX IP system to the Modem-Associated Device setting. You can program the analog line to modem-associated device in PGM 170.

The transferring baud rate in the PC and the baud rate of the Modem port (COM Port 3) in the SBX IP system must be identical. You can program the SBX IP system baud rate in PGM174. A baud rate of 9600 bps is recommended; 2400bps is available but slow, and 19200bps is also available but somewhat unstable.

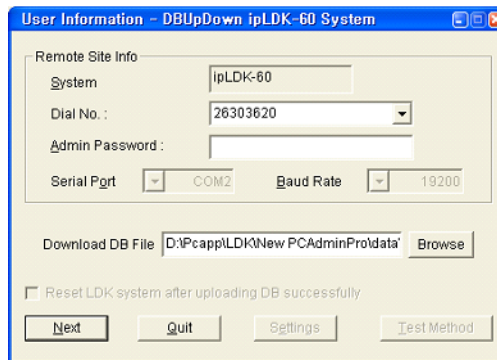

1. If you select a MODEM configuration, the next step is to set the following.
 - *Dial No.* -- Analog telephone number of the destination SBX IP system (see note).
 - *Admin Password* -- Required password to update MBU software.
 - *Range* -- The range of database, which you want to upload/download (such as All DB, LCR only, SPD only).
 - *Database File* -- The database file to be uploaded/downloaded.
 - *Valid* -- It displays the validity of the range of database, and pushing the "Check" button can check the validity.
 - *Check Button* -- Resets the SBX IP system after successfully uploading database. It is strongly recommended that you reset the SBX IP system after uploading any type of database.
2. Press the [Next] button to go to the next step.

Starting Database File Upload/Download

After setting the detailed configuration for the selected connection type, you are ready to start the SBX IP DB Upload/Download.

Choose one of the following:

- **Start:** Database transfer process will start.

NOTE: If you press the Start button at this point, all other buttons except the Monitor button will be disabled, and the ongoing progress will be displayed in the Monitor Trace window.

In a modem connection, after pressing the Start button, you have to select the details for the modem interface in the PC. Press OK to get started.

- **Back:** Go to the previous step.
- **Monitor:** Monitor Trace window.
- **Quit:** Program will be terminated.

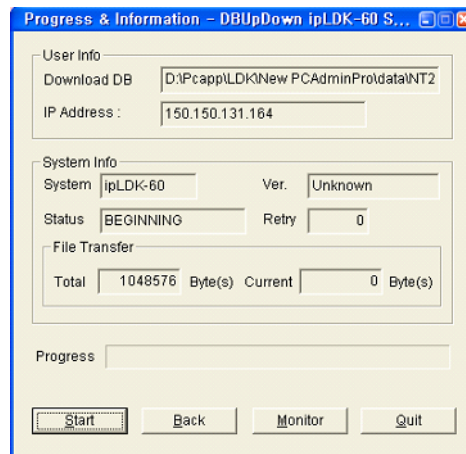
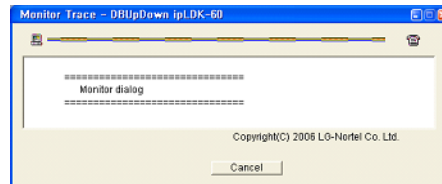

Transferring Process

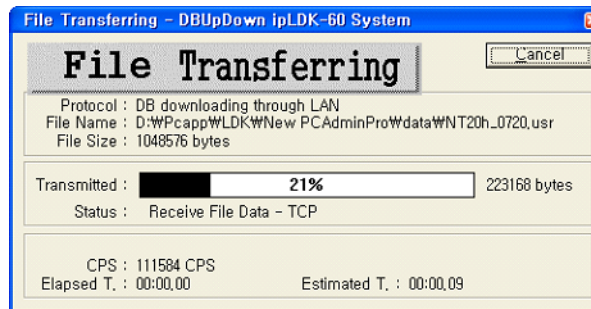

- During database file transfer a progress bar is displayed.
- Serial, Modem, and TCP connection use Z-Modem transfer protocol, and the sending process appears in the Z-Modem window.

NOTE: In version 3, TCP connection does not use Z-Modem transfer.

Finishing DataBase File Upload/Download

The results of the transfer is displayed upon completion of the transfer.

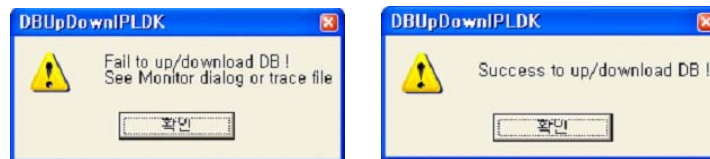

Once a transfer process is successfully completed, another upload/download process can be started.

IMPORTANT: It is strongly recommended that the SBX IP be reset after uploading any database.

NOTE: For more detailed information on using PC Admin, refer to the *PC Admin Guide*.

Loading a 2.5 Database into a 3.0 System

The following procedure shows the steps to load a **2.5 Database into a 3.0 system**, with two DTIB16s and a PRIB module using PC Admin 3.0.

Loading the Database

1. Default the system running 3.0 software by changing dip switch 1-4 to the ON position.
2. Set IP address for purpose of loading a database image -- Pre-Programmed > IP Setting (PGM 108).
3. *Reboot the system.*
4. Load 2.5 Database image.
5. *Reboot the system.*
6. Change the IP Address to the one the system will use for normal operation -- Pre-Programmed > IP Setting (PGM 108).
7. *Reboot the system.*

8. Initialize the Database as 3.0:
 - a. Go to Initialization (DB Int) > Initialization (PGM450/452).
 - b. Click the "Init. Ver. 3.0" button.
9. When the upload finishes, *reboot the system*.

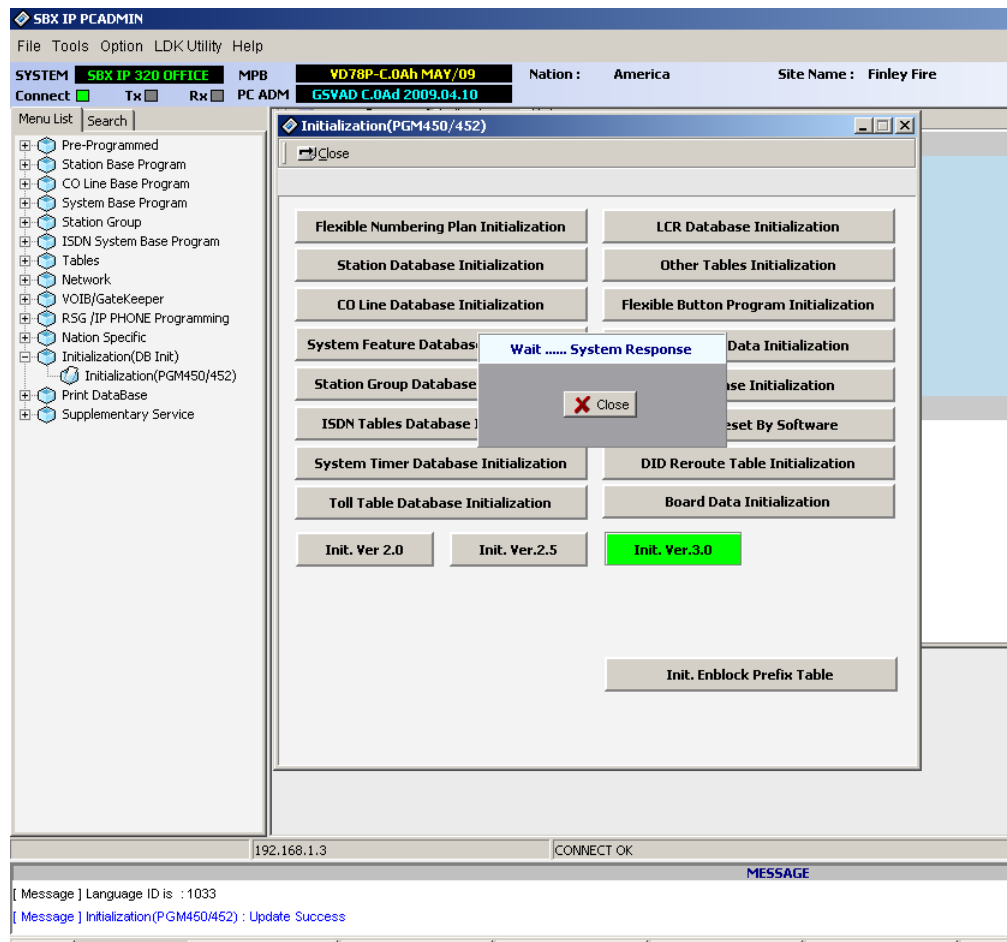

If you want to enter your Site information at this time:

- Go to Location Information (PGM100) and enter the name of the site in the Site Name field (up to 23 characters).
- The Nation Code will default to "America".

Example -- System Upgrade Configuration

After upgrading the system database, the system will need to be configured to add the new boards that were installed. This section shows how to configure an *SBX IP* system with a new PRI board and two (2) DTIB-16 boards using PC Admin.

Configure Boards

1. Go to Pre-Programmed > Configuration (PGM 101-103).
2. Right-click in "slot 3" and choose "Select Board / STA / DTIB16".
3. Right-click in "slot 4" and choose "Select Board / STA / DTIB16".
4. Right-click in "slot 6" and choose "Select Board / COL / PRIB".

BEFORE --

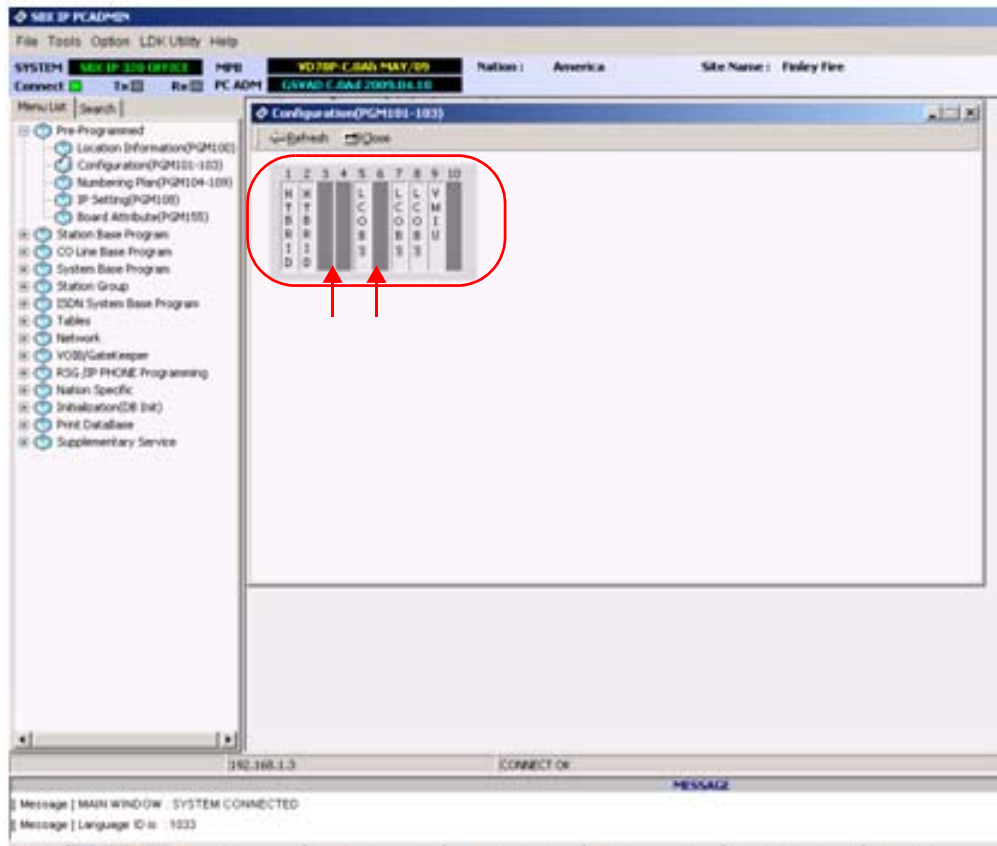

AFTER --

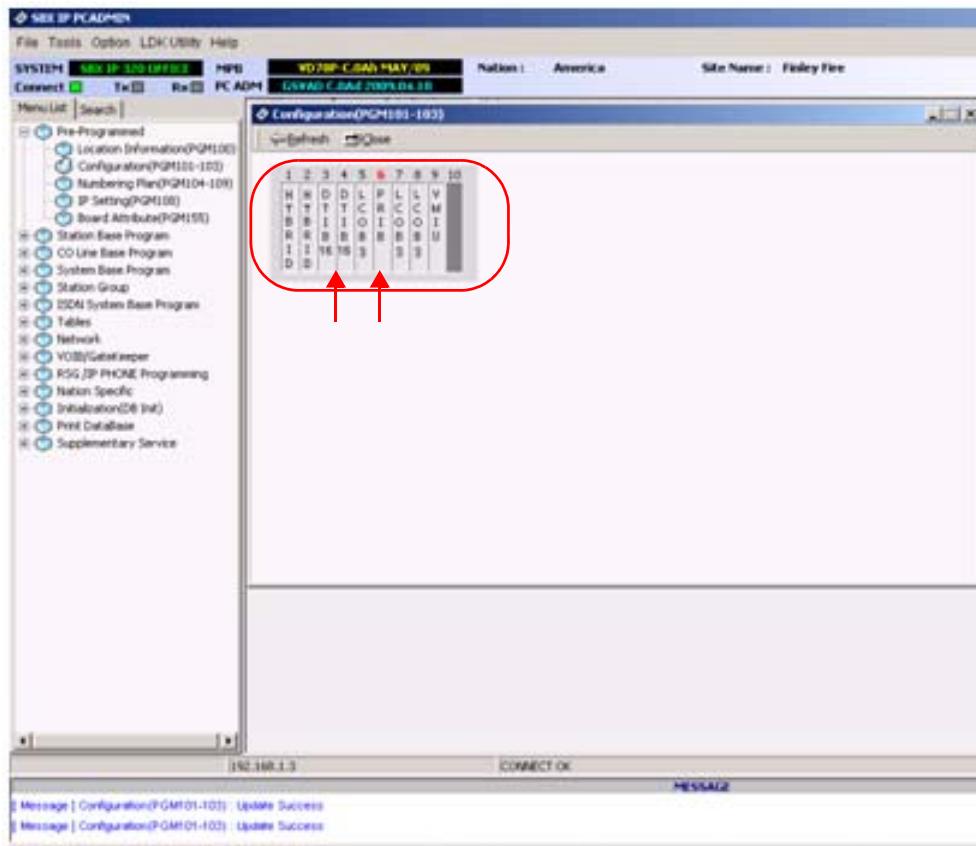

Configure Logical Assignments

1. In the board "Configuration" window (PGM 101-103) shown above, right-click and choose "Logical Assignment".
2. Next, right-click in the DTIB16 slot and select "Append to STA".
3. Repeat Step 2 for the second DTIB.
4. Then, right-click in the PRIB slot and select "Append to COL".

BEFORE --

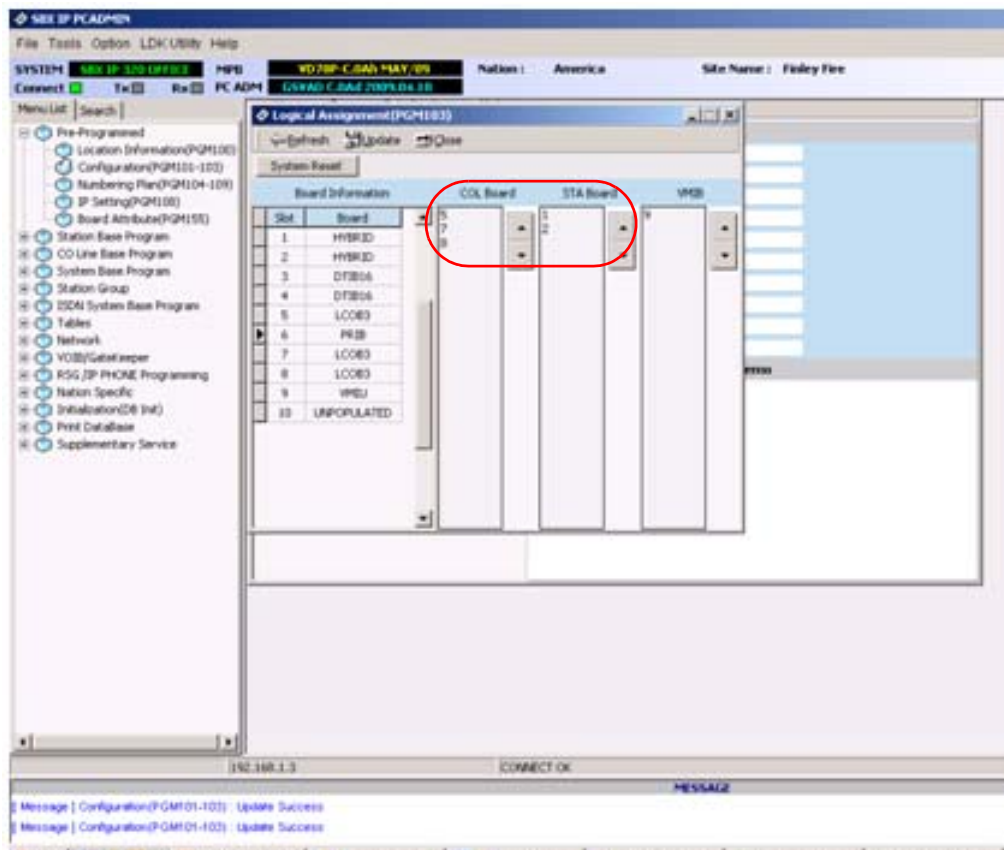

AFTER --

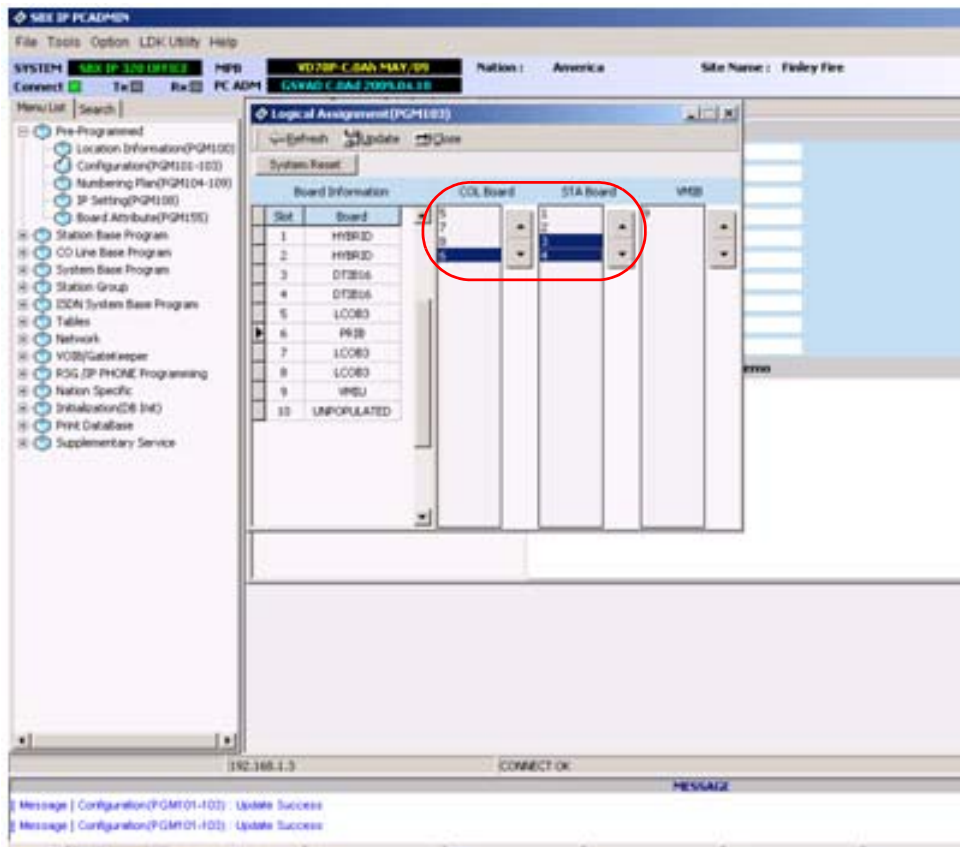

5. Once the Logical Board configurations have been made, reboot the system.

Configure Lines

PRI lines can have a different range depending on the boards installed.

1. When the system comes back on line, right-click in the PRIB slot in the board "Configuration" window shown above, and select "CO Data View" to see the range of PRI lines.
2. *From the Menu List*, select CO Line List (PGM 140/141/142/143) and set Lines 10 through 32 to "ISDN DID".

The screenshot displays the SBX IP PCADMIN software interface. The main window is titled "CO Line List (PGM 140/141/142/143)". The interface includes a menu list on the left, a main data table, and an "Update Tool" section at the bottom.

The menu list on the left includes the following items:

- Pre-Programmed
- Station Base Program
- CO Line Base Program
 - CO Line List (PGM 140/141/142)
 - CO Ring Assignment (PGM 141)
 - CO Line Attribute (PGM 140)
 - CO CID Attribute (PGM 147)
 - E1 CO Line Attributes (PGM 152)
 - SMS Attribute (PGM 292)
- System Base Program
- Station Group
- ISDN System Base Program
- Tables
- Network
- VOB/Gatekeeper
- RSG/IP PHONE Programming
- Nation Specific
- Installation (DB Init)
- Print Database
- Supplementary Service

The main data table displays the following columns: CO Num, Type, Day, Mrg, Night, Mrg, Weekend, Mrg, in-Demarc, Mrg, Signal Type, and Lurch. The table contains 26 rows of data, all with "ISDN DID" as the Type.

| CO Num | Type | Day | Mrg | Night | Mrg | Weekend | Mrg | in-Demarc | Mrg | Signal Type | Lurch |
|--------|----------|-----|-----|-------|-----|---------|-----|-----------|-----|-------------|-------|
| 10 | ISDN DID | | | | | | | | | | |
| 11 | ISDN DID | | | | | | | | | | |
| 12 | ISDN DID | | | | | | | | | | |
| 13 | ISDN DID | | | | | | | | | | |
| 14 | ISDN DID | | | | | | | | | | |
| 15 | ISDN DID | | | | | | | | | | |
| 16 | ISDN DID | | | | | | | | | | |
| 17 | ISDN DID | | | | | | | | | | |
| 18 | ISDN DID | | | | | | | | | | |
| 19 | ISDN DID | | | | | | | | | | |
| 20 | ISDN DID | | | | | | | | | | |
| 21 | ISDN DID | | | | | | | | | | |
| 22 | ISDN DID | | | | | | | | | | |
| 23 | ISDN DID | | | | | | | | | | |
| 24 | ISDN DID | | | | | | | | | | |
| 25 | ISDN DID | | | | | | | | | | |
| 26 | ISDN DID | | | | | | | | | | |

The "Update Tool" section at the bottom includes a "CO Num" field with a range of 10 - 32, a "Type" dropdown menu set to "ISDN DID", and "Update" and "Close" buttons.

At the bottom of the window, there are two message boxes:

```
Message | CO Line List (PGM 140/141/142/143) | Update Success
Message | CO Line List (PGM 140/141/142/143) | Update Success
```

3. Next, enter PGM 141 and set the Line Attributes as shown.

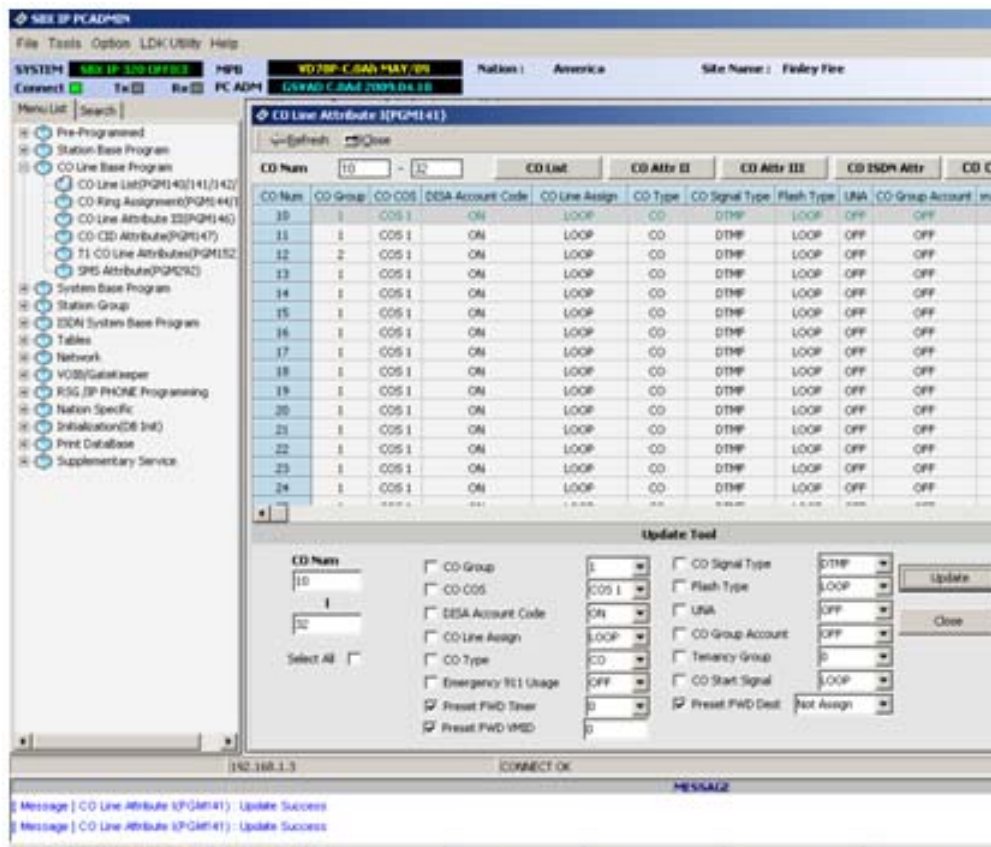

4. Then go to PGM 142 and set the Line Attributes as shown.

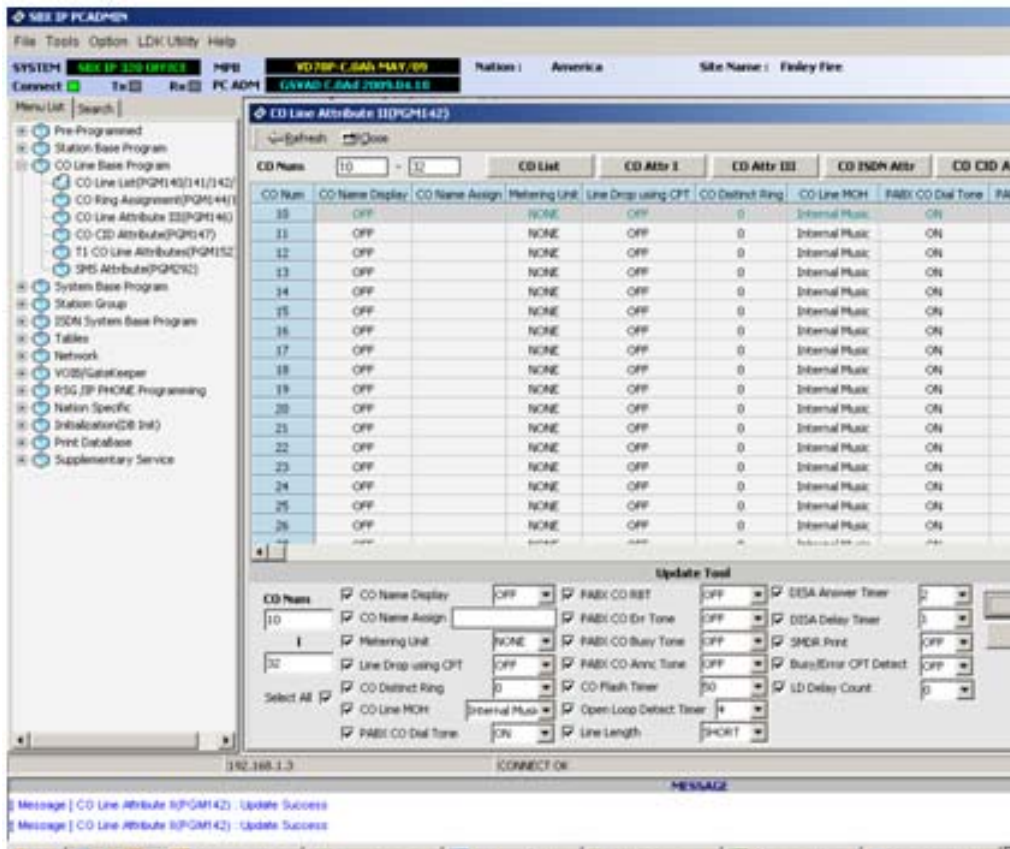

5. When finished, navigate to PGM 146 and configure the Line Attributes as shown.

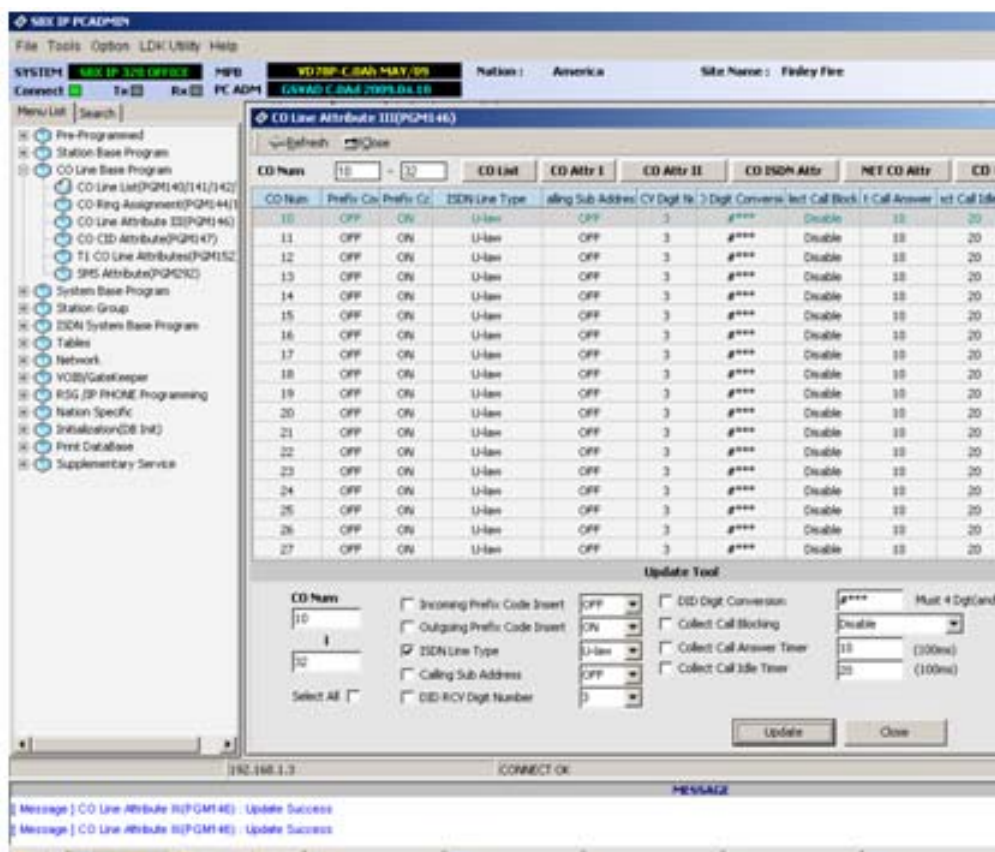

6. Then go to PGM 143 and set the Line Attributes as shown.

The screenshot shows the 'CD Line ISDN Attributes (PGM 143)' window in the SBX IP PC ADMIN application. The window title bar includes 'SBX IP PC ADMIN', 'File', 'Tools', 'Option', 'LDN Utility', and 'Help'. The main menu bar shows 'SYSTEM', 'MENU', 'PC ADMIN', and 'Site Name: Finley Fire'. The left sidebar contains a tree view of system components, with 'CD Line Base Program' selected. The main area displays a table of line attributes with columns for 'CD Num', 'CD Lnd', 'CD Attr I', 'CD Attr II', and 'CD Attr III'. Below the table is an 'Update Tool' dialog box with various configuration options.

| CD Num | CD Lnd | CD Attr I | CD Attr II | CD Attr III |
|--------|--------|-----------|------------|-------------|
| 10 | | | | |
| 11 | | | | |
| 12 | | | | |
| 13 | | | | |
| 14 | | | | |
| 15 | | | | |
| 16 | | | | |
| 17 | | | | |
| 18 | | | | |
| 19 | | | | |
| 20 | | | | |
| 21 | | | | |

The 'Update Tool' dialog box contains the following fields and options:

- CD Num: 10, 12
- COUP Table Id: []
- CLP Table Id: []
- Call Type: National
- DD Conv type: 2
- DD Remove Num: 0
- ISDN EMBLK Send: ON
- CLI Transit: CPW
- Double CLI Service: Transit
- Prefix Table Index (D-4): 0
- 3CLD Usage: OFF
- Num Plan for Calling: UNKNOWN
- Num Plan for Called: UNKNOWN
- ISDN SS CD: NO Service
- ISDN 1 Digit Remove: OFF
- ISDN OF Inband: OFF
- CLI Type (D-2): NORMAL
- Screening Indicator: 0
- Deny Incoming Call: OFF

Buttons: Update, Close

Message | CD Line ISDN Attributes (PGM 143) | Update Success

Message | CD Line ISDN Attributes (PGM 143) | Update Success

- The final step is to enter PGM 231 and set the entries in the Flexible DID Table based on the specific installation type. (The example shows the default settings.)

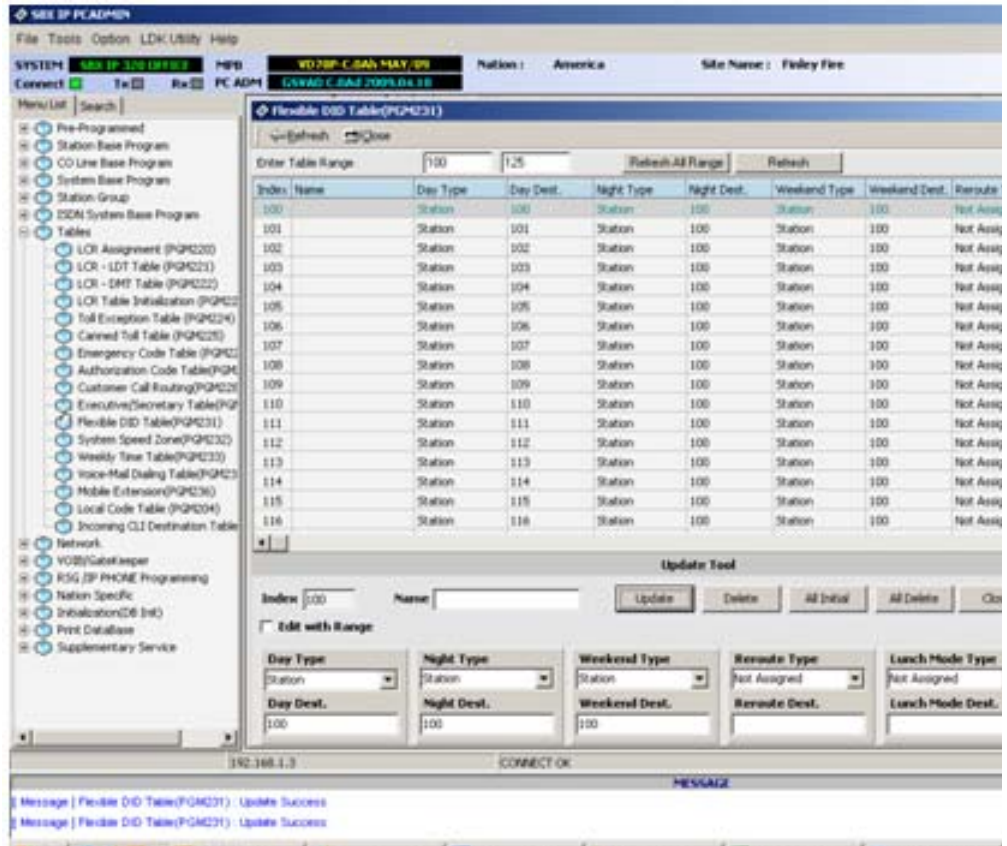

Upgrade Process

Software Upgrade

The PC Admin program is used to upgrade KSU software. Four connection types for PC Admin are available: TCP, Serial Web-based (for VoIB upgrade), and Modem connection. It is up to the user which connection method to use. These 4 types slightly differ by configuration, transfer speed, and transferring protocol.

Minimum PC Requirement

- PC OS: Windows 2000 or later
- PC Memory: 128 MB
- PC Free Disk Space: 10MB or higher (larger than 20MB is recommended)
- PC Monitor Resolution: VGA or higher
- PC Modem for analog phone lines only: General analog dial-up modem

Connection Method with SBX IP

SBX IP software upgrade is available by the following connection methods:

Serial Connection

SBX IP MBU software can be updated through RS-232C interface in PC.

TCP Connection

SBX IP MBU software can be updated through LAN interface at the remote PC.

Modem Connection

SBX IP MBU software can be updated through Modem interface at the remote PC.

Web-based

SBX IP MBU software can be updated through Web-based interface at the remote PC.

Installation

Upgrades for SBX IP are performed via PC Admin. Refer to *PC Admin Guide* for details regarding the installation of the PC Admin program for SBX IP.

File Component in the Execution Directory

If you install SBX PC Admin successfully and use a default installation, the following files will reside in the "execution" directory:

- PC Admin.exe: Main Execution File
- UpLDK.exe: Software Upgrade Tool
- DBUDLDK.exe: D/B Upload/Download
- LDKDiag.exe: Remote Diagnostics

NOTE: These files will be stored in the following folder: Program Files\Vertical Communications Inc\SBX PCADMIN\Admin

Choosing Up/Download and Connection Type

1. Select which system you are connecting to.
SBX IP upgrade is available through ISDN, TCP, Modem and Serial connection.
2. Choose the desired connection type.
A short dialog showing the requirements for the selected connection type will appear.
3. Check this basic requirement before getting started.

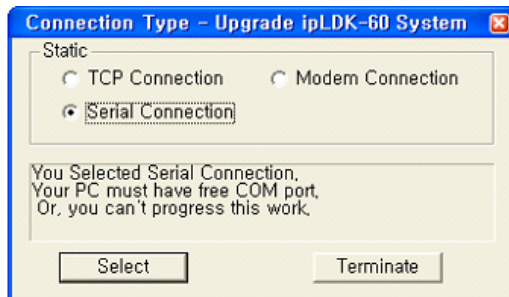
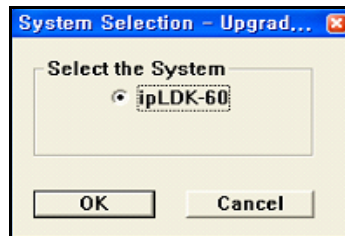

User Information Dialog

After selecting the desired connection type several configuration settings must also be made including Admin Password, Binary File etc. in the “User Information Dialog”. These settings differ slightly according to the selected connection type.

Up/Download by Serial Connection

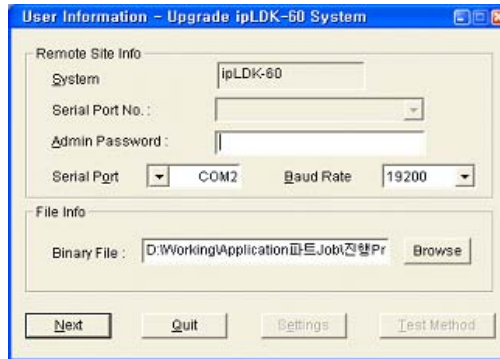

1. Enter the following entries for Serial connection:
 - *Serial Port* -- Serial port No. in PC connected to SBX IP COM port.
 - *Admin Password* -- If the SBX IP requires a password to update MBU software.
 - *Binary File* -- The new software file data to be updated.
 - *Baud Rate* -- Choose the transferring baud rate. (see note)

NOTE: The transferring baud rates for the PC and COM port in the SBX IP system must be identical. You can program the SBX IP system baud rate in PGM 174.

2. Press [Next] button to go to the next step.

Up/Download by TCP Connection

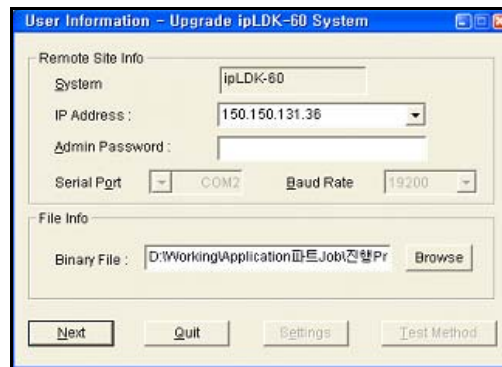

The screenshot shows a software configuration window titled "User Information - Upgrade ipLDK-60 System". It contains the following fields and controls:

- Remote Site Info:**
 - System: ipLDK-60
 - IP Address: 150.150.131.36
 - Admin Password: (empty)
 - Serial Port: COM2
 - Baud Rate: 19200
- File Info:**
 - Binary File: D:\Working\Application\업그레이드\Job\진행Pr
 - Browse button
- Buttons:** Next, Quit, Settings, Test Method

1. Enter the following entries for TCP connection:
 - *IP Address* -- IP address of the destination SBX IP system. (see note)
 - *Admin Password* -- If the SBX IP requires a password to update MBU software.
 - *Binary File* -- The new software file data to be updated.

NOTE: Assign SBX IP system IP address before you attempt to TCP connection. You can program the SBX IP system IP address in PGM 108.
2. Press [Next] button to go to the next step.

Upgrade by Modem Connection

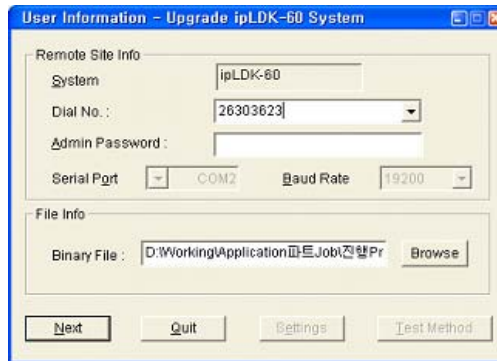

The screenshot shows a Windows-style dialog box titled "User Information - Upgrade ipLDK-60 System". It is divided into two main sections: "Remote Site Info" and "File Info".

- Remote Site Info:** Contains several input fields:
 - System:** A text box containing "ipLDK-60".
 - Dial No.:** A dropdown menu showing "26303623".
 - Admin Password:** An empty text box.
 - Serial Port:** A dropdown menu showing "COM2".
 - Baud Rate:** A dropdown menu showing "19200".
- File Info:** Contains one input field:
 - Binary File:** A text box containing the path "D:\Working\Application\업데이트\업Pr" and a "Browse" button to its right.

At the bottom of the dialog box, there are four buttons: "Next", "Quit", "Settings", and "Test Method".

1. Set the following entries.
 - *Dial No.* -- analog telephone number of the destination SBX IP system (see note).
 - *Admin Password* -- If SBX IP requires password to update MBU software.
 - *Binary File* -- The new software file data to be updated.

NOTE:

Before you attempt a Modem connection, assign the analog telephone number of the SBX IP system to the Modem Associated Device setting using PGM170.

The transferring baud rate in the PC and the baud rate of the Modem port (COM Port 3) in the SBX IP system must be identical. You can program the SBX IP system baud rate in PGM174. A baud rate of 9600 bps is recommended; 2400bps is available but slow, and 19200bps is also available but somewhat unstable.

PSTN network can cause the modem to be disconnected.

2. Press [Next] button to go to the next step.

Starting Software Upgrade

After setting the detailed configuration for the selected connection type, you can begin the software upgrade:

1. Choose one of the following:

- Start.: Database transfer process will start.

NOTE: If you press the Start button at this point, all other buttons except the Monitor button will be disabled, and the ongoing progress will be displayed in the Monitor Trace window.

In a modem connection, after pressing the Start button, you have to select the details for the modem interface in the PC. Press OK to get started.

- Back: Go to the previous step.
- Monitor: Monitor Trace window.
- Quit: SBX IP software upgrade program will be terminated.

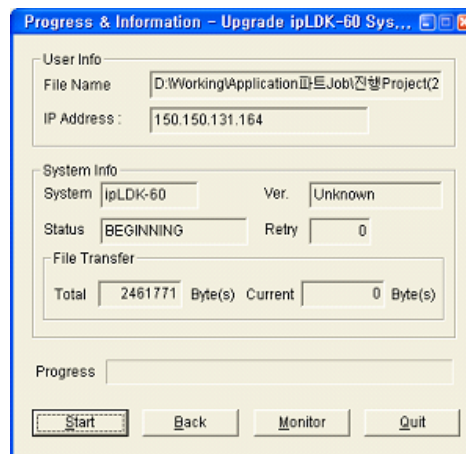
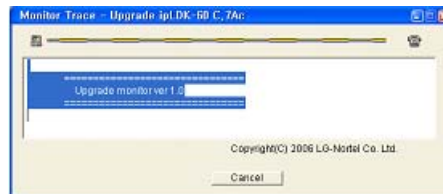

Transferring Process

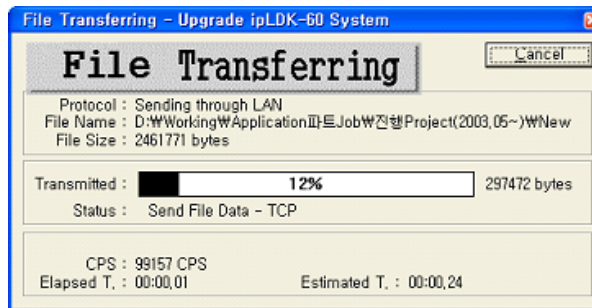

- When the software file transfer is undergoing, you can monitor the process. In an ISDN connection you can see the transferring process in the Monitor Dialog window. Serial, Modem, and TCP connection use Z-Modem transfer protocol, and the sending process appears in the Z-Modem window.

NOTE: In version 3, TCP connection doesn't use Z-Modem transfer.

Completing Software Upload

Before the upgrade is actually begun, transfer of the files as previously described must be completed. After successful completion of file transfer, the "Wait Dialog" will be displayed. This means that the SBX IP system software upgrading is beginning.

- During the upgrade process, all stations are inoperable.
- After the upgrade process, the SBX IP system should automatically reset itself and be ready for use. The reset takes a several minutes.

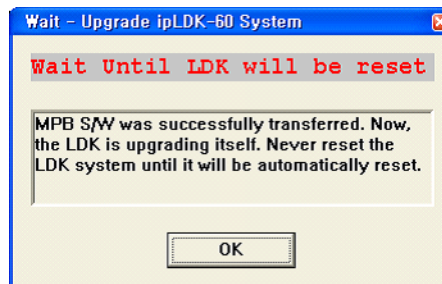

- You can start another upgrade upon successful complete of on upgrade, you can immediately begin another.

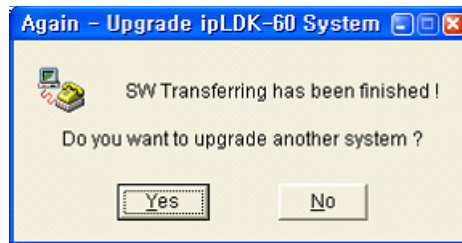

NOTE: If the file transferring process fails, a Fail message appears. The reason for the failure will appear. Check the Troubleshooting section of this guide or contact Vertical Technical Support for assistance.



Uploading new VMIB prompts

When upgrading an SBX IP system, it is sometimes necessary to upload an updated set of VMIB prompts. This is the case when upgrading from Release 2.5 to Release 3 software.

Prerequisites:

- The SBX IP must be programmed with an IP address for the local network (PGM 108) and must be connected.
- VMIB must be installed in the system (see [page 4-21](#)).
- The appropriate voice prompt file (*.bin) must be obtained from Vertical (contact Vertical Technical Support).

Upgrading Voice Prompts

1. Place a copy of the VMIB prompt file on drive C:\ as shown here:

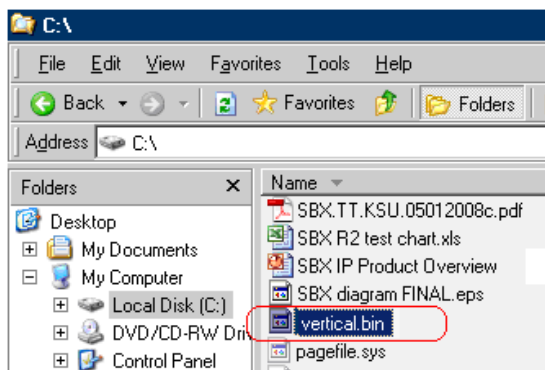

2. Launch an FTP client application. The following example shows the Windows command-line FTP client.
 - Log on to the SBX system via FTP.
<EXAMPLE>
c:\>ftp 172.19.15.70
Connected to 172.19.15.70
220 FTP Server ready.
User (172.19.15.70:(none)): admin
331 Password required for admin.
Password: admin(hidden)
230 User logged in.
ftp>
 - In ftp command mode
ftp> bin
200 Type set to I
ftp> hash
Hash mark printing On ftp: (2048 bytes/hash mark).
ftp> put <file_name>
(note: file_name = prompt file name, in this case, vertical.bin)

226 Transfer complete. Trace 3
ftp: 1454080 bytes sent in 29.91Seconds 48.62Kbytes/sec.
ftp>
3. Once the file transfer is complete, close the FTP session.
4. From PCAdmin, use the Remote Diagnostic tool to connect to the SBX system via TELNET or SERIAL connection.
5. Enter "maint" mode (password: brandy).

- Verify that the prompt file is on the virtual disk (that is, enter the commands 'file' and then 'dir c':

```
ipLDK-60 System
Version GS88P-C.7Ao JUN/08
Dsp Version: 3.0(06/06/29)
DATE: 6/05/08
TIME: 13:35:35
SITE NAME   :
ENTER PASSWORD: *****
maint> file
maint>file> dir c
```

You should see the following:



The screenshot shows the SBX Remote Diagnostic Tool interface. The title bar reads "SBX Remote Diagnostic Tool". The menu bar includes "File", "Connection", "Commands", "View", "PhoneBook", and "Hel". Below the menu bar is a toolbar with various icons. The main window displays the following text:

```
Your address is 172.19.5.81. Your p
SBX IP 320 System
Version GS78P-B.0Ab JUN/08
Dsp Version: 5.2(07/08/14)
DATE: 06/05/08
TIME: 11:26:43
SITE NAME   :
ENTER PASSWORD: *****
maint> file
maint>file> dir c
file name
-----
vertical.bin
>>> Total 1 file(s) exist on disk!
>>> Total 711680 bytes are availabl
maint>file>
```

Red circles highlight the "ENTER PASSWORD: *****", "file", "dir c", and "vertical.bin" entries in the screenshot.

7. Use "x" to exit the file menu back to the maint menu

```
maint>file> x
```

```
maint>
```

```
file name
=====
vertical.bin
>>> Total 1 file(s) exist on
>>> Total 711680 bytes are av
maint>file> x
maint>
```

8. Burn prompt file to VMIB using this command: fp i vertical

```
maint>fp i Vertical
```

You should see this:

```
vertical.bin
>>> Total 1 file(s) exist on disk!
>>> Total 711680 bytes are availab
maint>file> x
maint>
maint>
maint> fp i vertical
VMIB PROMPT PROGRAM SUCCESS!!
```

9. Reboot the system.

VoIB Software Upgrade by Web-based Connection

1. Connect the serial port of VoIB and enter the maintenance window.
2. Enter "dir c", then press Enter.
3. Check to see if any files exist. To delete a file, type "del c: [file name]."
4. Connect via browser to the VoIB's IP address.

```
maint> dir c
Empty disk!
maint>
```

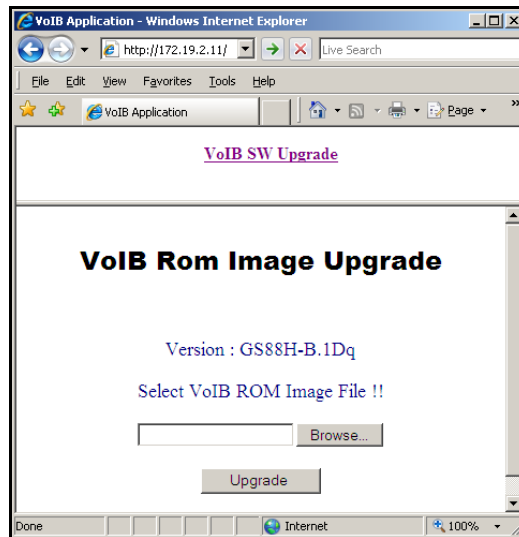
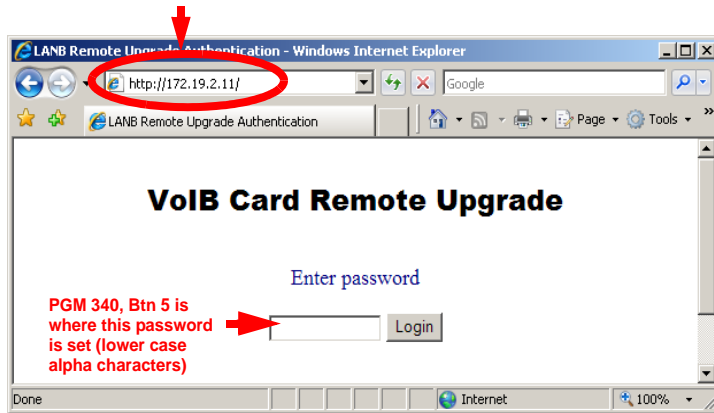

5. Browse to locate the Rom file.

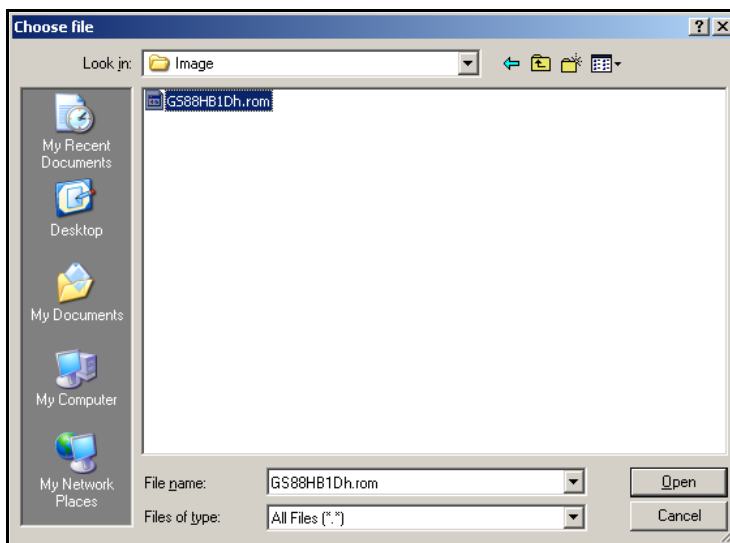

6. Select the Rom file, then click Open.

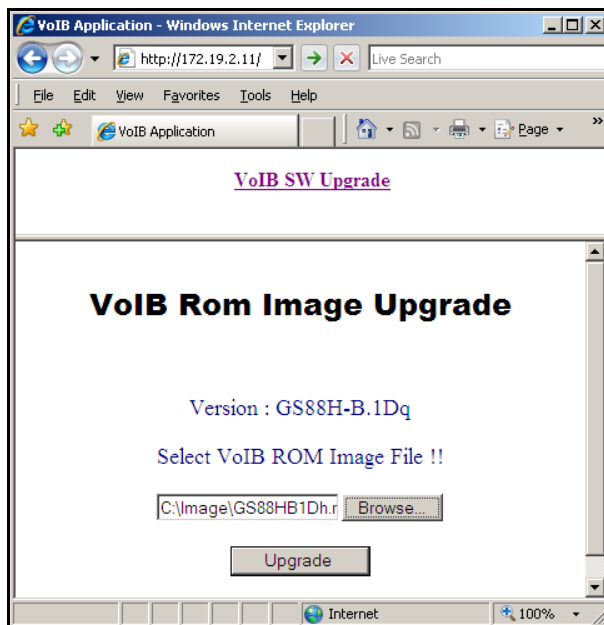

- Click the Upgrade button.

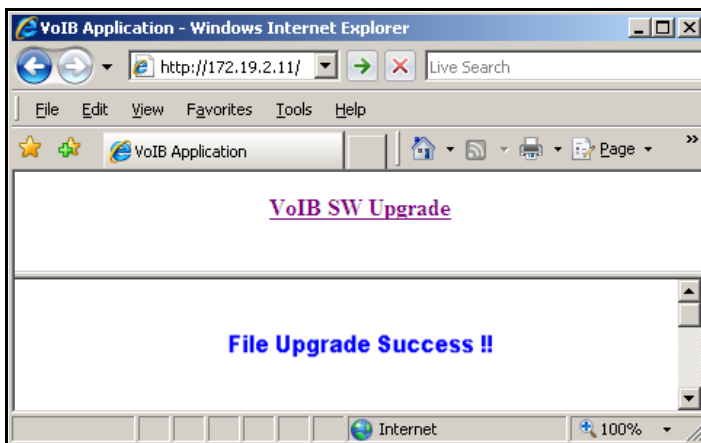

- Optional: To verify that the file was uploaded, connect to the KSU via serial port and type the command "dir c:"

The filename is changed into '_File_VoIB60_pack_on_disk'

Example:

```
maint> dir c
file name                               size(bytes)  LSAD\shr(attr)
=====
_File_voib60_pack_on_disk               1050156      0-----
>>> Total 1 file(s) exist on disk!
>>> Total 32391168 bytes are available on C drive!
maint>
```

T1/PRI Firmware Upgrade

Verify network settings

Before starting the upgrade process, check the IP addresses entered in PGM 155 to make sure they are correct (aka: FLEX buttons 3, 4, and 5):

- IP Address
- Gateway Address
- Subnet Mask

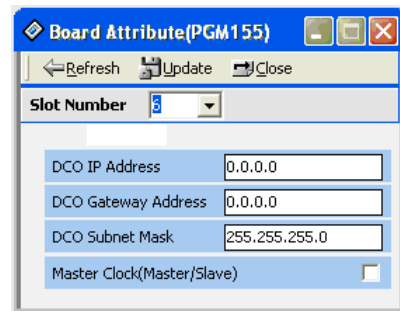

Downloading firmware file

Using the HTTP Download method to upgrade the SBX IP T1/PRI firmware:

1. Enter "http://" followed by the IP Address of the T1/PRI card in the web browser address box.
2. Click the "Browse..." button and select the SBX IP T1/PRI firmware file.
3. Then click "Upload" to transfer the SBX IP T1/PRI firmware to the SBX IP system.

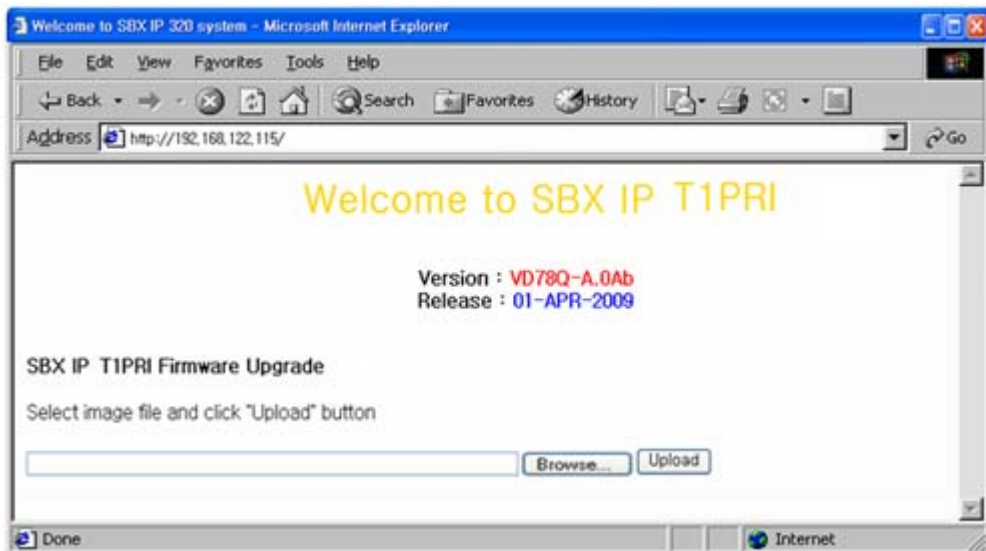

- Click “Proceed Flash Update” to start upgrading the SBX IP T1/PRI firmware. The upgrade process normally takes less than 5 minutes to complete.

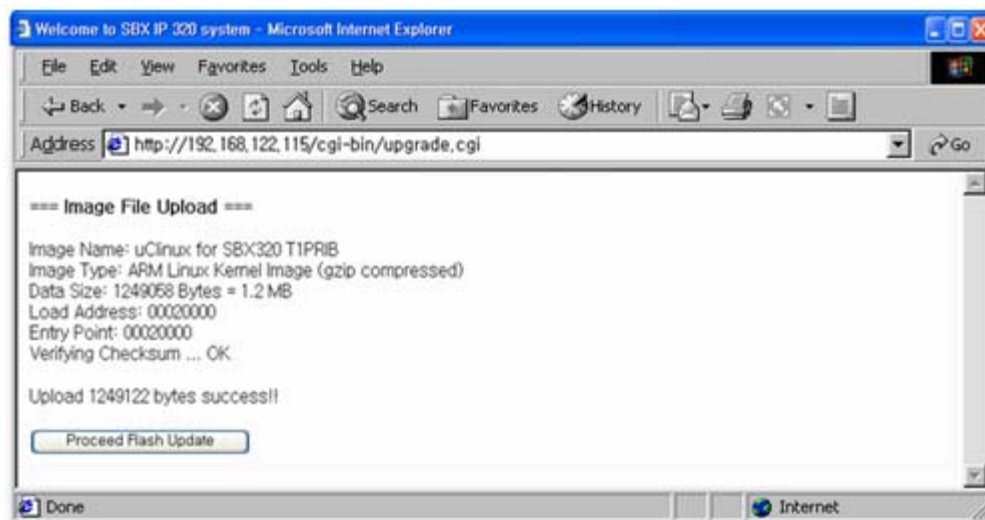

- If upgrading is finished successfully, the T1/PRI board starts to reset automatically.

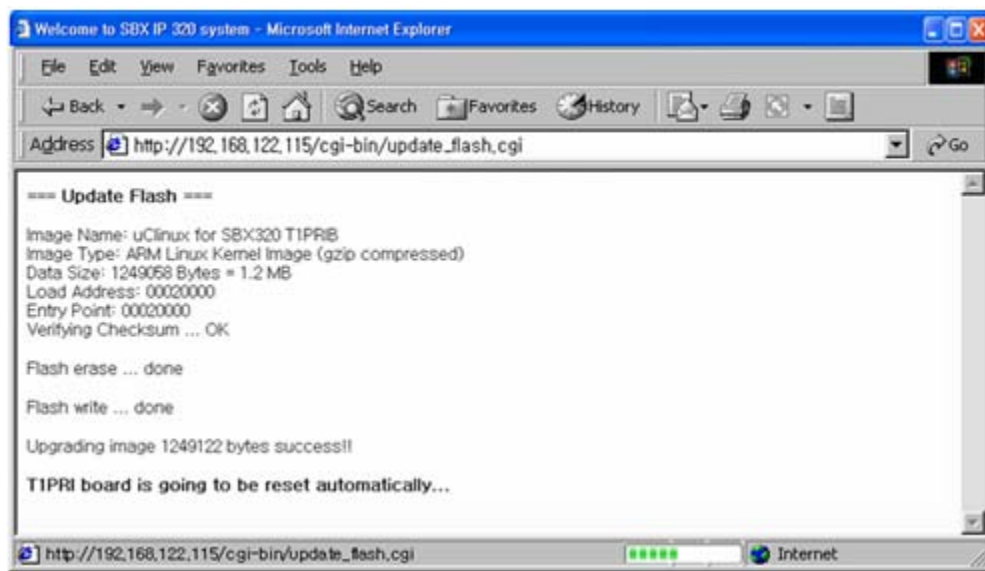

Remote Diagnostics

The SBX IP Remote Diagnostic Tool is a MS-Windows application program that may be used with PC Admin program. Remote Diagnostics is used for diagnosing problems of the SBX IP system, and also maintaining the system from a remote site. Remote Diagnostics can send and receive the results of diagnostic commands of the SBX IP system such as GSXD test, Board configuration, Software reset count, Station status, CO status, Station recovery, CO recovery, Version display, Help message, and Log out.

Introduction

Hardware/Software Minimum Requirements

The system minimum requirements for using Remote Diagnostics are as follows:

SBX IP

- Serial Port installed on MPB as a basic option
- LAN Port installed on MPB for LAN connection
- Unique IP Address assigned for LAN connection
- MODU installed on MPB

PC

- Pentium Celeron 233MHz CPU or higher CPU
- 256 color Super VGA (800 x 600) or higher
- One or more Serial Port
- NIC (Network Interface Card) for LAN Connection
- 2 button Mouse
- At least 32MB RAM
- MS-Windows 95/98/2000/me/XP/NT
- Enough hard drive space for installation

Cable

- RS-232C Type Cable for connecting the PC and the SBX IP system: Two connectors are needed for this connection. One connector should be a 9-pin female connector to be connected to the SBX IP, and the other one should fit the serial port of the PC. In addition, there are three required lines that must be connected for the communication between the PC and the SBX IP system: Ground-Ground, Transmit-Transmit, and Receive-Receive.
- If an external modem is used for the PC, a serial cable is needed for the connection between PC and modem. Refer to the modem users manual for information about making the connection.
- If an NIC is used for a LAN connection, a UTP cable with an RJ-45 Jack between the PC and the SBX IP system is required.

Hardware Configuration

For serial connection, the PC must be connected to the basic serial port of the SBX IP system.

For modem connection, a MODU must be installed in the SBX IP system, and a modem must be installed on the PC.

For LAN connection, a crossover CAT5 or higher cable must be used when connecting directly to the SBX LAN port from a PC.

NOTE: Use a straight-through cable if connecting via LAN or WAN.

Installing Software

Once the hardware is installed, you are ready to install the software.

Microsoft Windows must be installed on the computer before you install SBX IP Remote Diagnostic Tool program. For information on installing Windows, refer to applicable user's manual.

Remote Diagnostic software is included with the PC Admin software package. So, the PC admin software package **MUST** be installed in order to use remote diagnostic software.

Uninstalling Software

To uninstall the SBX IP Remote Diagnostic Tool program, you may use the Add/Remove utility including in the Control panel of MS-Windows. If the SBX PC Admin Package, the associated Remote Diagnostic software will also be uninstalled.

Important Notes for Users

- SBX IP Remote Diagnostic Tool is installed with the PC Admin program.
- To use a modem connection with Remote Diagnostics, TAPI and TAPI32 Dynamic-Link Library and TAPISRV.EXE must be installed in MS-Windows. These files are installed in most of the PCs in which MS-Windows is installed.
- If any files were create after the installation of this Remote Diagnostics, they may not be deleted when you uninstall SBX IP Remote Diagnostic Tool. For example, PhoneNo.txt is a file that is created after the Save button is clicked on Phone Number dialog. Other files may be saved or backup files, etc.
- If the GSXD Test command is executed on the system that does not use a GSXD chipset, the result of the GSXD Test shows an error message appears.
- To log on to the SBX IP system after logging out, click the Enter button in the Input Box Bar.
- When Remote Diagnostics is executed, some components (i.e. buttons in Command Bar) may be hidden unless you enlarge or maximize the window.
- If a button label is too long for the Command Bar, it may be broken into two lines to accommodate the short space.

Full Screen Layout

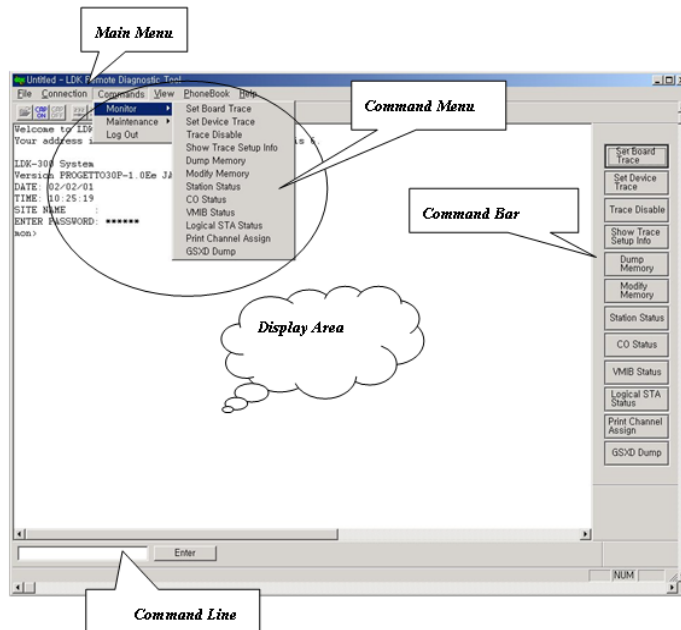

File Menu

The File menu includes Open, Save, Save As, Print, Print Preview, Print Setup, and Recent Files that are file related operations.

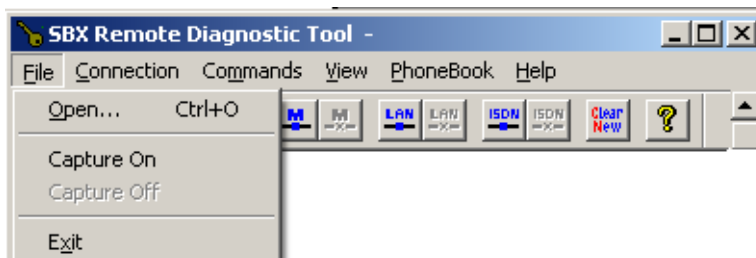

Open Sub-menu

1. Select Open sub-menu in File menu.

Open dialog appears.

Or you can use the tool button  in the Toolbar to execute the same command.

2. Select one of the saved files (file extension is *.dat).
3. Click OK.

The dialog is closed, and the contents of the file is displayed in the Data Display Area.

Capture On Sub-menu

1. Select the Capture On sub-menu in the File menu.
Save As dialog appears.
2. Enter a different file name.
3. Click OK.

Capture Off Sub-menu

Select Capture Off sub-menu in the File menu.

Connection Menu

The SBX IP system and Remote Diagnostics can be connected in three ways, Serial, Modem, or LAN.

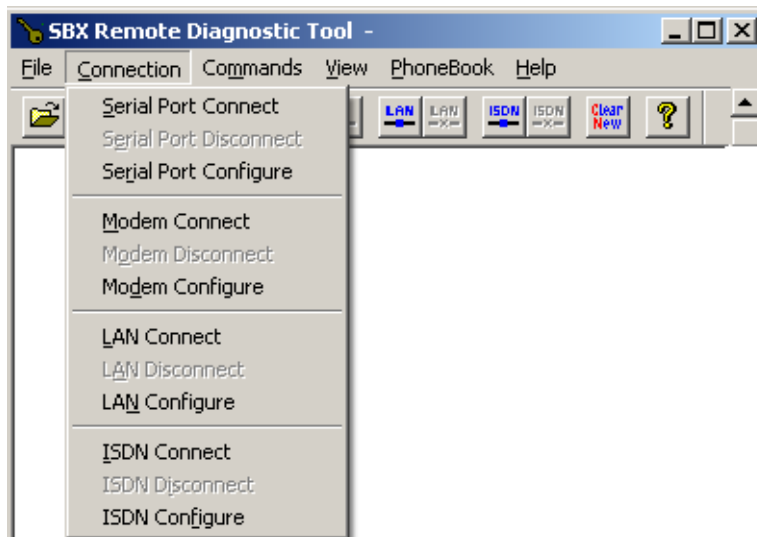

Serial Port Connection with SBX IP System

For the serial port connection between the PC and the SBX IP system, there must be a physical connection with an RS-232C standard serial cable.

- The pins used in connection cable should be connected as follows;
Transmit: Transmit of both the system and the PC must be connected.
Receive: Receive of both the system and the PC must be connected.
Ground: Ground of both the system and the PC must be connected.
- The length of connection cable depends on the communication environment of the system. In normal conditions, the cable length is limited to 15 meters. In certain conditions, a 30-meter cable can be used.
- If the SBX IP system is connected to the serial port on the MPB, select one of the transmission rates - 2400bps, 4800bps, or 9600bps.

Serial Port Configure Sub-menu

Serial Port Configure is for configuring the serial port of the PC that is to be connected to the SBX IP system.

- When the serial port connection is established, this menu becomes unavailable
- Setting values are stored for the next session, at which time they are automatically restored and used.

Procedure

1. Select Serial Port Configure sub-menu in the Connection menu.

The Serial Port Configuration dialog appears.

2. Enter the following values:
 - Port: Select connection port to be connected to the SBX IP
 - Baud Rate: Select one of 2400bps, 4800bps, 9600bps. Selected Baud Rate must be same as that of the SBX IP
 - Parity: Select None
 - Data Bits: Select 8
 - Stop Bits: Select 1
 - Flow: All of DTR/DSR, RTS/CTS, XON/XOFF are not to be checked.
3. Click OK.

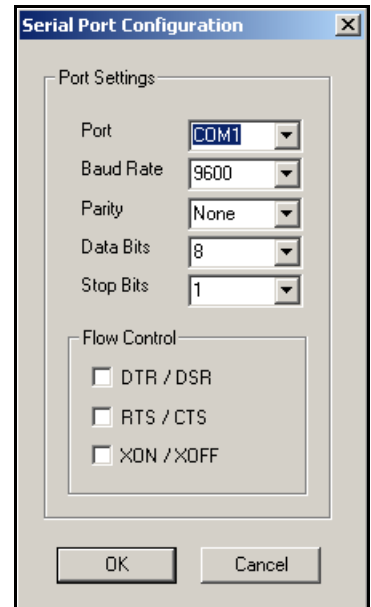

Serial Port Connect Sub-menu

Serial Port Connect connects the serial port of the PC and the SBX IP system with the setting values from Serial Port Configure.

If the connection fails when another program is using the serial port or the port does not exist, an error message appears.

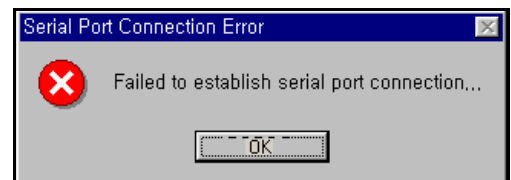

If the connection is successfully established, a confirmation message appears. The success of connection means that the connection between Remote Diagnostics and the serial port of the PC is successfully established.



However, this does not mean the connection between Remote Diagnostics and the SBX IP system is successfully established.

If the serial port is already connected, the sub-menu and the tool button for serial port connection cannot be selected.

Procedure

1. Select Connection menu.
2. Select Serial Port Connect in Connection menu.

-or-

Use the tool button  in the Toolbar to execute the same command.

Serial Port Disconnect Sub-menu

Serial Port Disconnect disconnects the serial port connection between the PC and the SBX IP.

Conditions:

- If the two serial ports are already disconnected, the menu and the toolbar for serial port disconnection cannot be selected.

Procedures:

1. Select the Connection menu.
2. Select the Serial Port Disconnect sub-menu in the Connection menu.

-or-

Use the tool button  in the Toolbar to execute the same command.

Modem Connection with the SBX IP System

Modem connection between the PC and the SBX IP system requires either an internal or an external modem on the PC. Modem installation does not only mean the physical connection between PC and modem, but all the associated setup procedures (such as installing a device driver file for MS-Windows).

Modem Configure Sub-menu

Modem Configure is for configuring the PC modem that is to be connected to the SBX IP system.

Conditions:

- When the modem connection is established, you cannot select this menu. The menu item is disabled in this case.
- The MODU must be installed on the MPB of the SBX IP system (see [page 4-15](#)).
- By clicking the Configure button in Modem Configuration dialog, you can select or change various settings for the modem configuration:
 - The setting values are effective only during the execution time of Remote Diagnostics and are not stored for the next execution.
 - Those values do not affect the modem settings of MS-Windows itself. To change modem configuration, use the Control Panel in MS-Windows. The changed settings from the Control Panel are applied to all application programs using the modem.

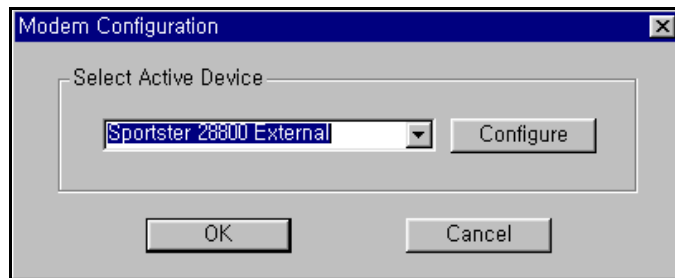

Procedure:

1. As per the Conditions listed above, select or change modem settings by using Control Panel as needed.
2. Select the Modem Configure sub-menu in the Connection menu.
The Modem Configuration dialog appears.
3. Choose appropriate settings from the following:
 - Select Active Device: Select a modem that is to be used for modem connection with the SBX IP system. The setting value is stored and used the next time this procedure is executed.
 - Configure button: Set the detailed modem configurations. The setting values are effective only during the current procedure, and are not stored for the next execution. These values do not affect the modem settings of MS-Windows itself.
4. Click OK.

Modem Connect Sub-menu

Modem Connect establishes modem connection using values from Modem Configuration (see above).

Conditions:

- If a connection failure occurs when improper installation of the modem, turning-off state of the modem, busy state of the destination, or various telecommunication problems that may occur during the session, an error message is appears.
- If an invalid/unavailable or incomplete phone number is entered or the destination does not answer, the connection is dropped after the time limit set for the Time-out value in Modem Configure.
- When making a modem connection, a Call Status dialog window appears showing the status of the modem call. The call status messages are sent from the modem or modem device driver. Therefore, the messages in the Call Status dialog window may differ from modem to modem. The Call Status dialog window can be hidden by clicking the Hide button in the Call Status dialog window.

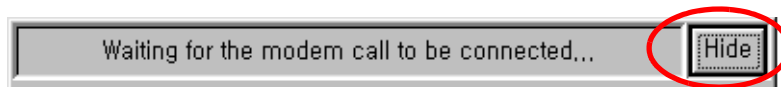
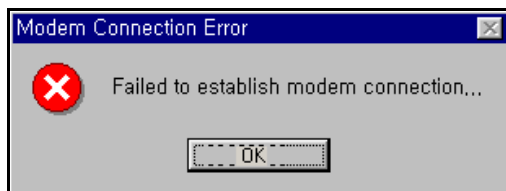

- When the modem connection is established, the Modem Connect menu is unavailable.

Procedure

1. Select the Modem Connect sub-menu in the Connection menu.

Phone Number dialog appears.

-or-

Use the icon  in the toolbar to execute the same command.

2. Use the Phone Number dialog to enter a phone number and make a modem call to a destination by (refer to the description below for detailed explanation about how to use Phone Number dialog).

A confirmation message appears to let you know whether or not the connection was successful or if it failed.

Phone Book

The Phone Book is used for entering / storing phone numbers and making a modem call to a destination.

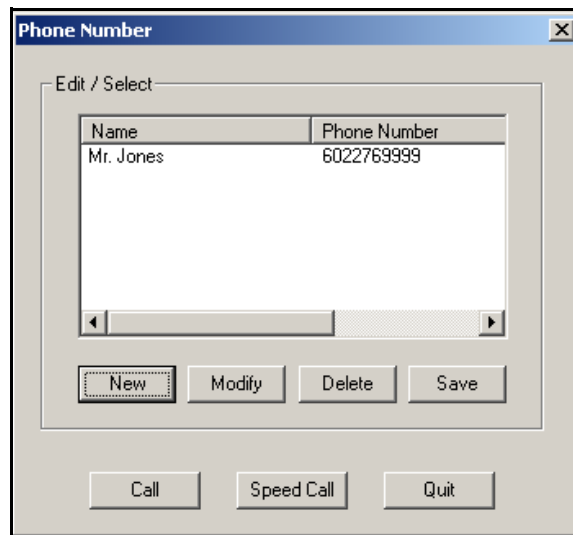

Procedure:

To open the Phone Book, click the Modem Connect sub-menu.

To close the Phone Book, click the Quit button.

To enter a new phone number:

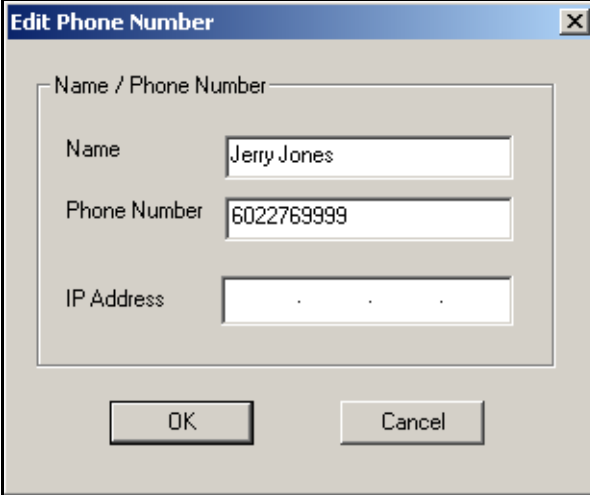

1. Click the New button to enter a new phone number.

Edit Phone Number dialog appears.

2. Enter the name and phone number (maximum of forty characters each).

NOTE: The following special characters cannot be entered for the Name: (), [], and ; (that is no parentheses, brackets or semi-colon). Only numbers and characters on the keypad can be used for the number (0 to 9, *, and # - see Dialable Characters on [page 9-16](#)).

3. Click OK to complete the entry.

-or-

Click the Cancel button to cancel the input.

4. Click Save to store the new phone numbers into a PhoneNo.txt file for future use

IMPORTANT: If you close the Phone Number dialog window without clicking the Save button, the newly entered phone number will be lost.

To modify an existing phone number:

1. In the Phone Number List Box, click the name associated with the number you want to edit.
2. Click the Modify button.
The Edit Phone Number dialog appears.
3. Edit the name and phone number as needed (maximum of forty characters each).

NOTE: The following special characters cannot be entered for the Name: (), [], and ; (that is no parentheses, brackets or semi-colon). Only numbers and characters on the keypad can be used for the number (0 to 9, *, and # - see Dialable Characters on [page 9-16](#)).

4. Click OK to complete the changes.

-or-

Click the Cancel button to cancel the changes (the number will remain saved in its existing form).

5. Click Save to store the edits.

If you close the Phone Number dialog window without clicking the Save button, the edits will not be stored.

To delete an existing phone number:

1. In the Phone Number List Box, click the name associated with the number you want to delete.
2. Click the Delete button.
A Delete Confirmation Message Box appears.
3. Click OK.

-or-

Click the Cancel button to prevent the deletion (the number will remain saved in its existing form).

4. Click Save to permanently delete the number.

If you close the Phone Number dialog window without clicking the Save button, the deletion will not be made.

IMPORTANT: When storing the contents of the Phone Number List Box into a txt file as described above:

- the contents of the Phone Number List Box are saved in a PhoneNo.txt file located in the same directory as the main program files.
- DO NOT edit this file directly. Doing so will result in all of the data being lost. You must ONLY USE the procedures shown above to make additions, edits, and deletions.
- It is recommended that no more than one-thousand (1000) phone numbers be stored in this file for optimum performance. However, Remote Diagnostics does not check and limit the number of phone numbers. Therefore, you may want to manually monitor this file, and use the deletion procedure shown above to delete any unnecessary numbers to keep the file below its maximum capacity.

To make a modem call using the Phone Number List:

1. In the Phone Number List Box, click the name associated with the phone number you want to dial.

Hint: You can also double-click on this item, then skip to step 3 (without clicking the Call button).

2. Click the Call button in the Phone Number dialog.

A Call Information Message Box appears.

3. Click OK to start dialing.

-or-

Click the Cancel button to stop the call.

To make a modem call with the Speed Call button:

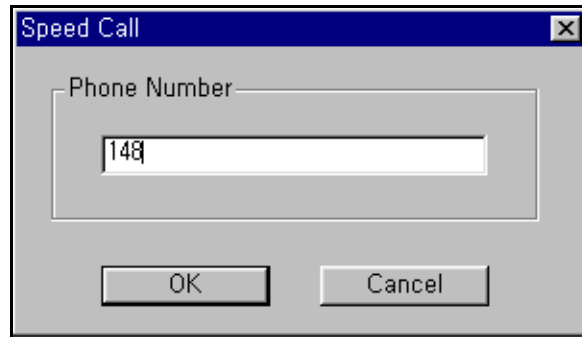

1. Click the Speed Call button in the Phone Number dialog.

A Speed Call dialog appears.

2. Enter the phone number in the Phone Number field.

NOTE: Only Dialable Characters can be used - see [page 9-16](#)).

3. Click OK.
4. The Call Information Message Box appears.
5. Click OK to start dialing.

-or-

Click the Cancel button to stop the call.

Dialable Characters

Dialable characters are used to enter a phone number that can be dialed.

- 0 - 9 A - D * # = DTMF and/or pulse digits.
- ! = performs a hook-flash (one-half second on hook, followed by one-half second off hook before continuing).
- P p = causes pulse dialing of the digits that follow this indicator.
- T t = causes tone (DTMF) dialing of the digits that follow this indicator.
- , = pauses dialing. The duration of a pause is device specific. Multiple commas can be used to provide longer pauses.
- W w = indicates that dialing should proceed only after a dial tone has been detected.
- \$ = indicates dialing is to wait for a "billing signal" (such as a credit card prompt tone).

IMPORTANT: Not all dialable characters work for all modem dialing. Refer to the user manual included with the modem being used for more information.

Modem Disconnect Sub-menu

Modem Disconnect ends the modem connection.

Conditions:

- When the modem connection is dropped, this menu is unavailable.

Procedures:

1. Select the Connection menu.
2. Select the Modem Disconnect sub-menu.

-or-

Use the icon  in the Toolbar to execute the same command.

A confirmation message appears to let you know if the disconnection was successful or not.

IMPORTANT: The success of serial port connection means that the connection between this Remote Diagnostics and the serial port of the PC succeeded. This does not mean the connection between Remote Diagnostics and the SBX IP system succeeded.

Even though a serial port or modem connection is inadvertently disconnected or some other reason, Remote Diagnostics does not detect this. Instead, a command is sent to the SBX IP system, then a message box appears (as if the call is unanswered).

If a modem connection is not established after a period of time that was set in Modem Configure as a time-out value, no further attempts are made to make a modem connection, and an error message appears.

LAN Connection with the SBX IP System

The SBX IP provides several methods for administering the system, including via TCP/IP using its (included) Ethernet port.

For the LAN connection between a PC and the SBX IP system, there must be a physical connection to the local network with 10BaseT cable.

Vertical supports the following configuration methods for administering the system via the LAN port:

- Direct connection using a crossover UTP cable - see below.
- Connection via Local Area Network using a straight UTP cable - refer to ["Connection To KSU Over a LAN Switch," on page 9-24](#)

Direct Connection

The following procedure shows how to make a direct connection to the KSU via crossover patch cable, with no LAN switch:

1. Set the PC's LAN port to the following settings:
 - Speed: 10 Mbps
 - Duplex: Half
 - IP address: 192.168.1.2
 - Subnet Mask: 255.255.255.0
 - Default Gateway: leave blank

NOTE: Once connected, the PC may auto-negotiate to 10 Mbps/Half duplex to match the KSU. In this case, you don't need to make the speed and duplex settings shown above.

(Continued on next page)

2. Make sure that the KSU's LAN port is at its default configuration (IP Address 192.168.1.1)
3. Connect an Ethernet crossover cable directly between the PC and the KSU's LAN port as shown in Figure 9-1.

KSU IP Address: 192.168.1.1

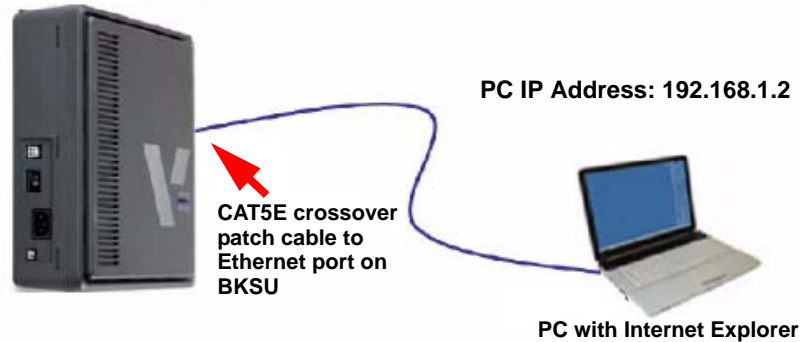
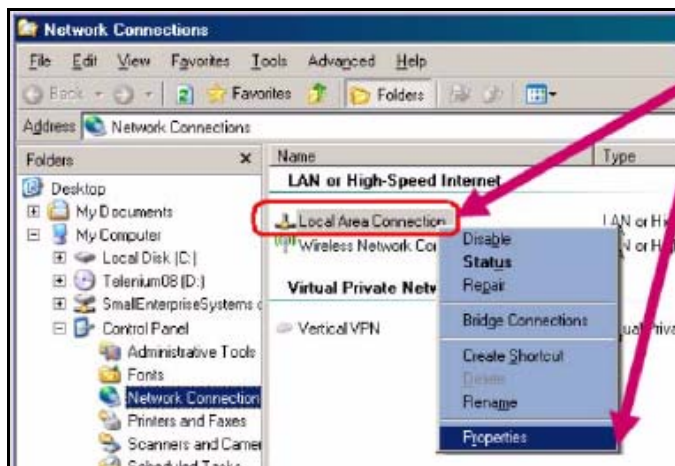

Figure 9-1 Direct Connection with Crossover Patch Cable

Example Computer/LAN Setup

The following procedure for setting up uses the example of a typical Windows PC running Windows XP Professional:

1. Open Network Connections.
2. Right-click the connection corresponding to the RJ-45 connection.
3. Select Properties.



4. In the Connection Properties dialog box, select TCP/IP.

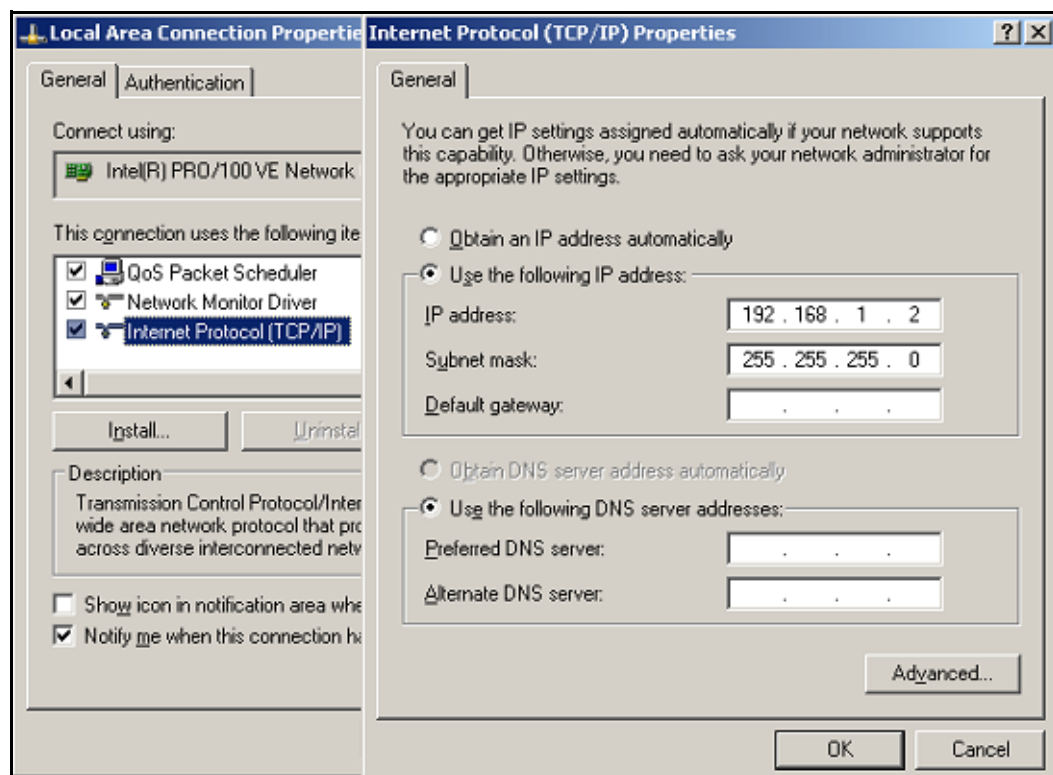

5. Set the address as shown above.
6. Click OK.

7. Click the Configure button.

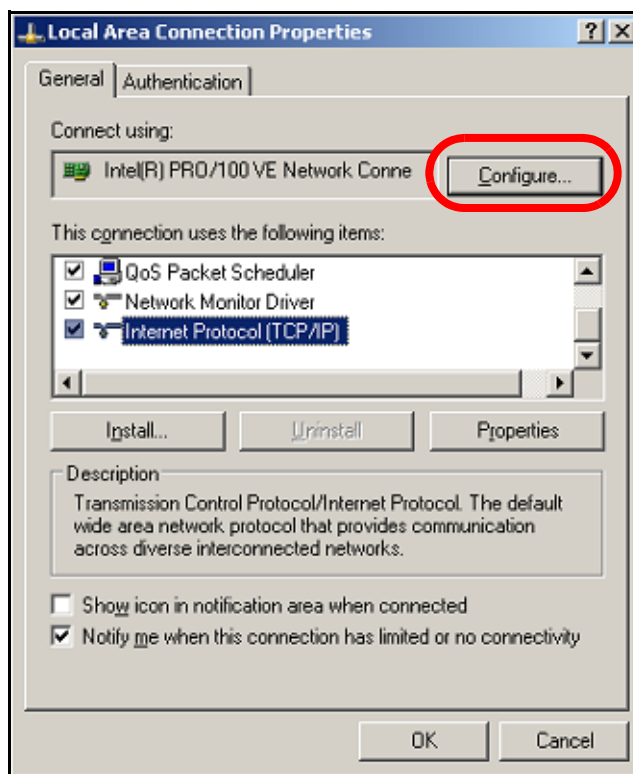

8. Under the Advanced tab, click Speed & Duplex.
9. Select 10 Mb Half.

10. Click OK.

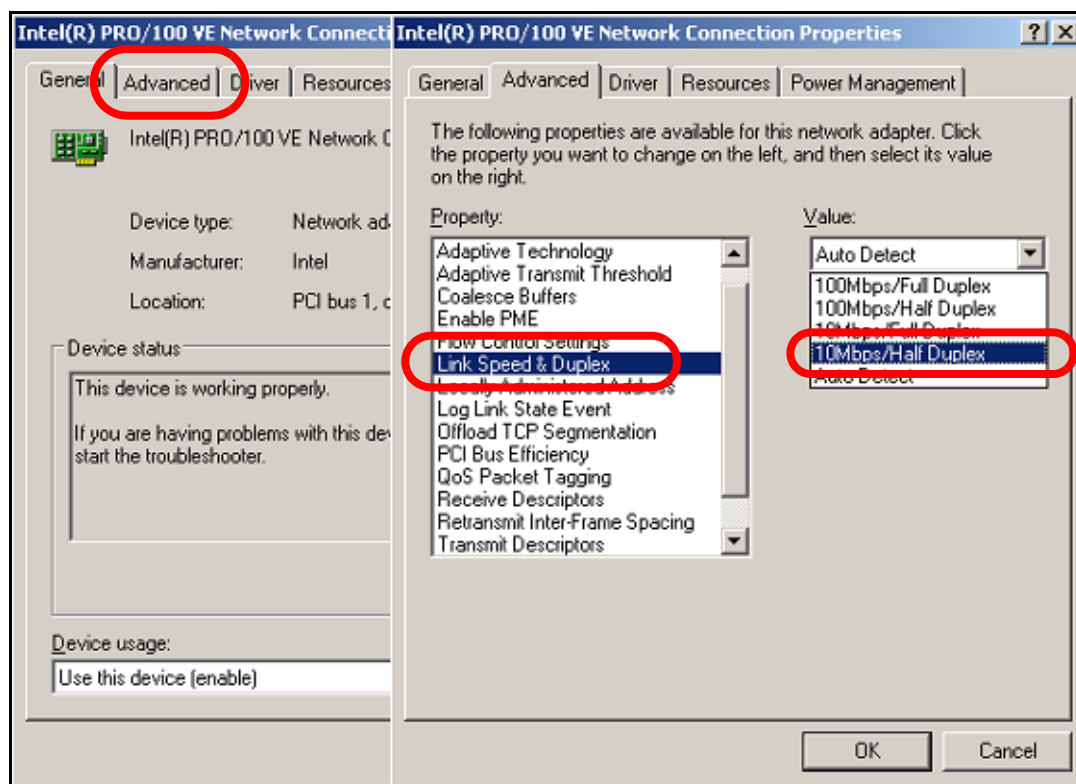

11. Click OK again to close the Connection Properties dialog.

To test the direct connection using the ping command:

1. From Windows, go to Start > Run.
2. Enter the following:
CMD.
3. Click OK.
4. At the command prompt: enter the following: ping 192.168.1.1
5. Press Enter/Return.
You should see a result like the one shown below.

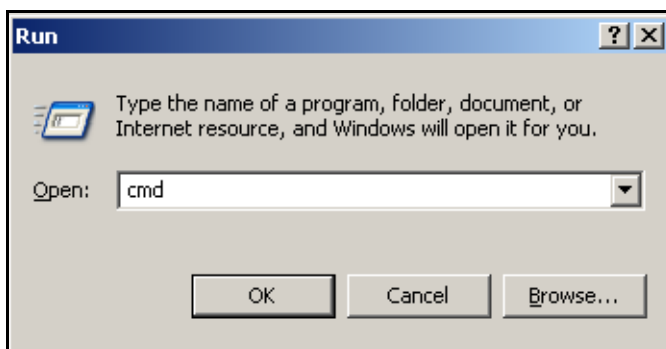

```
C:\>ping 192.168.1.1

Pinging 192.168.1.1 with 32 bytes of data:

Reply from 192.168.1.1: bytes=32 time=3ms TTL=64
Reply from 192.168.1.1: bytes=32 time=1ms TTL=64
Reply from 192.168.1.1: bytes=32 time=1ms TTL=64
Reply from 192.168.1.1: bytes=32 time=2ms TTL=64

Ping statistics for 192.168.1.1:
    Packets: Sent = 4, Received = 4, Lost = 0 (0% loss)
    Approximate round trip times in milli-seconds:
        Minimum = 1ms, Maximum = 3ms, Average = 1ms

C:\>
```

Connection To KSU Over a LAN Switch

1. Plug the KSU's LAN port into the LAN switch via a Category 5E or higher straight-through patch cable.
2. Change the KSU to match the LAN addressing scheme using PGM 108.

-or-

Set the PC's LAN port to the following settings:

IP address:192.168.1.2

Subnet Mask:255.255.255.0

Default Gateway:leave blank

NOTE: The BKSU's default IP address is 192.168.1.1.

NOTE: Modify settings as appropriate for the specific local network.

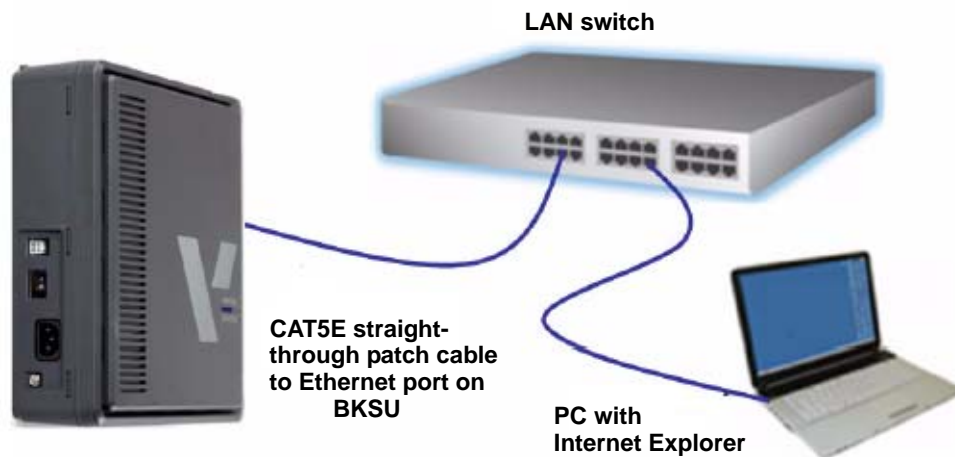

Figure 9-2 Direct connection over LAN

Conditions:

- The SBX IP system and PC must have valid IP addresses.
- A crossover UTP cable is required for direct connection. This means that the Transmit and Receive are crossed. However, you connect the SBX IP system and PC with a Hub. In addition, you can use a normal UTP cable that is used in the local network.
- To connect from a different segment of the LAN or from an external site (via Internet), the SBX IP system must have a valid gateway address (default router), otherwise a remote connection using TCP/IP is not possible.
- Connecting to the SBX IP system at a remote site, may require assistance from the network administrator, since many sites use a firewall/NAT/PAT in their router.
- In a remote connection using the Internet, connection speed/stability is dependent on the environment of WAN traffic or routing.

Additional Support

If you require additional assistance or have questions regarding this topic, please contact Technical Support at 1-877-VERTICAL (837-8422), Option 4.

LAN Configure Sub-menu

LAN Configure is for configuring the destination IP address that is to be connected to the SBX IP system.

Conditions:

- Once the LAN connection is established, this menu is unavailable.
- Setting values are stored for the next session at which they are automatically restored and used. But only one IP address will be saved.

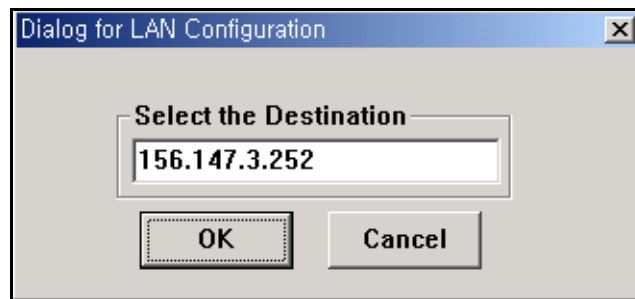

Procedures:

1. Select the LAN Configure sub-menu in the Connection menu.
The LAN Configuration dialog appears.
2. Enter the destination IP address.
3. Click OK.

LAN Connect Sub-menu

LAN Connect connects the PC and SBX IP system with the IP address set in the LAN Configure sub-menu (see above).

Conditions:

- An error message appears if no connection is made because the IP address is not valid, that the SBX IP system does not have an IP address, or errors were made when the IP address was entered.
- A confirmation message appears when a connection is successfully established. A successful connection means that the connection between Remote Diagnostics and the NIC of the PC was completed. However, this does not mean that the connection between Remote Diagnostics and the SBX IP system succeeded.

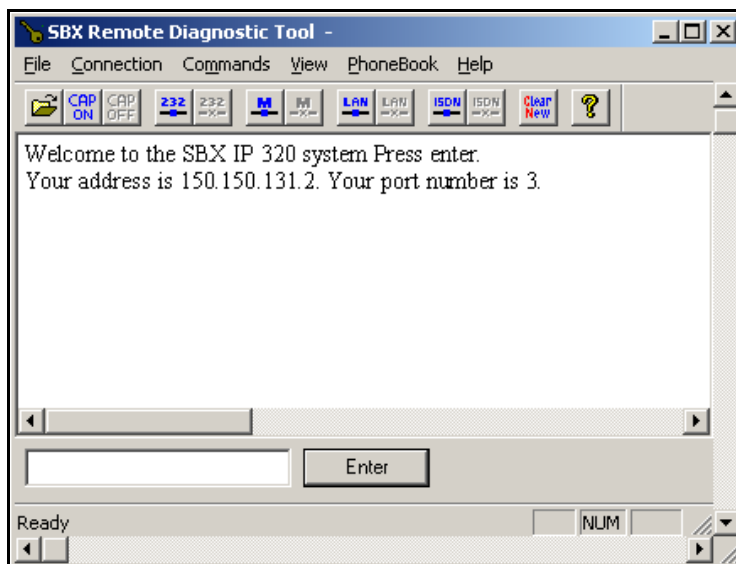

- If the LAN port is already connected, the sub-menu and the tool button for LAN connection cannot be selected.

Procedures:

1. Select the Connection menu.
2. Select LAN Connect in the Connection menu.

-or-

Use the icon  in the toolbar to execute the same command.

LAN Disconnect Sub-menu

LAN Disconnect disconnects the LAN connection between PC and SBX IP.

Conditions:

- If the LAN connection is already disconnected, the menu and the toolbar for LAN disconnection cannot be selected.

Procedure:

1. Select the Connection menu.
2. Select the LAN Disconnect sub-menu in the Connection menu.

-or-

Use the icon  in the toolbar to execute the same command.

Commands Menu

During connection, Remote Diagnostics can send commands to the SBX IP system to get diagnostic results. It reads these command configurations from the CmdConf.txt file that is installed with the executable file. In addition, it uses the data for Menu, Command Bar, and Input Box Bar. The CmdConf.txt file is a command configuration file, and the contents of the file follow special rules for command configuration.

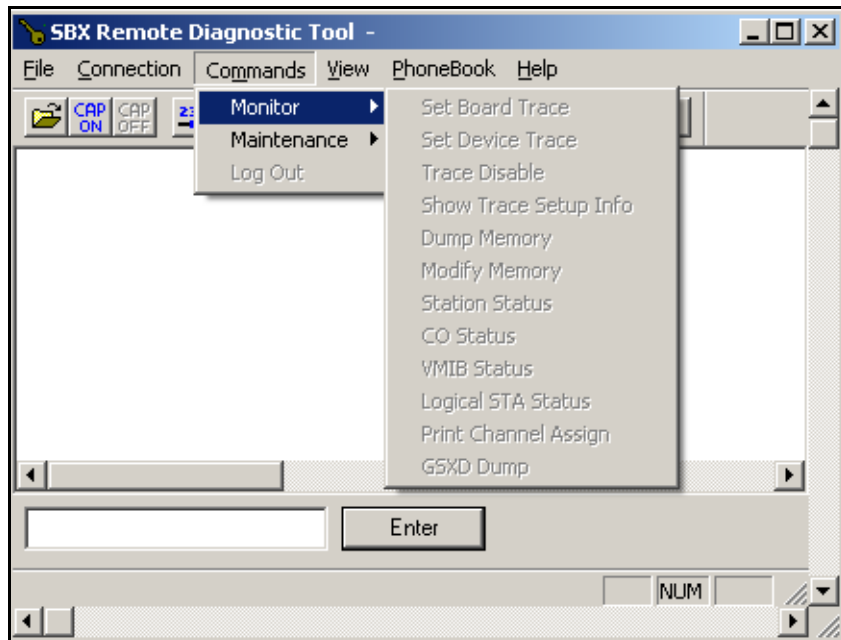

Executing Commands

The following is a description of how set commands for execution.

NOTE: Remote Diagnostics does not check the validity of the command argument that is needed for some commands, and error handling is done within the SBX IP system.

Using Commands Menu

The Commands menu includes all the commands from the CmdConf.txt file.



Procedure

1. Select the Commands menu.
The Commands sub-menu is shown.
2. Click on the command to be executed.

NOTE: If the selected command requires an argument, the Enter Command Argument dialog appears. You will need to enter the appropriate argument in the field. The argument is limited to 6 characters. Once a valid argument is entered the command is executed.

Using Command Bar

Procedure

1. In the Command Bar, click the button of the command to be executed.

NOTE: If the selected command requires an argument, the Enter Command Argument dialog appears. You will need to enter the appropriate argument in the field. The argument is limited to 6 characters. Once a valid argument is entered the command is executed.

Using Input Box Bar

The Input Box Bar can be used to execute almost any monitoring and diagnostic commands supported by the SBX IP system. Command usages and limitations follow the SBX IP system specification.

The Input Box Bar can be docked on the top or bottom of the current window.

Procedures for Using SBX IP Command Edit Box and Enter Button



1. Make sure the cursor is in the Command Edit Box field.
If it isn't, click on SBX IP Command Edit Box so that the input cursor is blinking inside the box.

2. Input the command in the Command Edit Box.

NOTE: The command is limited to 40 characters.

3. Click the Enter button, or press the Enter key on the keyboard, to send the command to the SBX IP system.
 - If step 3 is attempted when the Command Edit Box is empty, a character corresponding to the Enter Key is sent to the SBX IP system.
 - If you want to log in to the SBX IP system after logging out from Maintenance or Monitor mode, click the Enter button to display the login/password dialog. You can then log in.
 - When use the Command Edit Box to try to execute a remote command (r-type command) that needs an argument by typing the command in SBX IP, you also need to type the argument with the command; the Enter Command Argument dialog is not provided.

Functions of Commands

Commands provided by the SBX IP system are:

Monitor Commands are available when you log on using "jennie" as the password.

| | |
|--------------------------------|-------------------------|
| ? | - Help menu |
| t b xx | - Set Board Trace |
| t c e h t (s c d t v #xxx) a r | - Set Device Trace |
| t d | - Delete Trace Info |
| t p | - Show Trace Setup Info |
| d addr1 addr2 | - Dump Memory |
| m addr xx | - Modify Memory |
| s ### | - STA Status |
| c ### | - COL Status |
| v ### | - VMIB Status |
| l ### | - Logical STA Status |
| p vs | - Print Port Assign |
| gsxd dump all | - GSXD dump |
| x | - Exit monitor |

Remote Commands are available when you log on using "brandy" as the password.

| | |
|-----------------------------|-------------------------------------|
| ? | - Help Menu |
| bc | - Display Board Configuration Table |
| bl | - B-channel Listening |
| bs ## | - View Board Status |
| dbdedr | - Display Diagnostic Result |
| hd | - Display HDLC Status |
| log view clear | - Log view or clear |
| reboot | - Remote System Reset |
| setsw oos nor ## | - Set Service Switch |
| ta allperiodatdcallsum..... | - Traffic Analysis |
| ts | - Display Time-slot Assigment |
| up | - Software Upgrade |
| vc sua... | - VMIB Annc/Usr Greeting Clear |
| ws ? | - WTIB Statistics |
| x | - Exit Command |

The database command detail information is as follows:

| | |
|---------------|-------------------------------------|
| db cc | - Configuration Constraint |
| db pf | - Pre-Programmed Fault |
| db ts | - Time-Slot Conflict |
| db ht | - highway Test Pre-Programmed Fault |
| db dt | - DTRU Test |
| db ct | - CPTU Test |
| db mt | - Memory Test |
| db rt | - RTC Test |
| db pc | - Power Capacity |
| db rc | - RGU Capacity |
| de hs | - HDLC Status |
| dr is/ic | - ISDN Line Status |
| dr ri/rc | - Reset Information |
| dr li d/c/v/a | - Resource Assignment |

Monitor - Set Board Trace

Sets trace for board in a specific slot xx. The trace is entered as:

mon>t b xx (where xx is the number of the board)

For example, when setting trace for board in slot 7 you would enter the following:

Monitor - Delete Trace Info

Deletes all current trace commands and reverts to idle condition.

Monitor - Set Device Trace

Sets trace for device.

Command options are as follows:

- c: device COMMAND tracing. (MP PP)
- e: EVENT tracing. (PP, Internal, Timer Event)
- h: HIGHWAY tracing.
- t: CTI device command / event tracing.

Device options are as follows:

- S: Tracing related to station
- C: Tracing related to CO
- D: Tracing related to DTMF
- T: Tracing related to CPTU
- V: Tracing related to VMIB channel

For example, if you want to trace the Station 102 for Cmd, Evt and highway information, you would enter the command option with physical station number as following;

```
mon>t ceh s002
```

NOTE: At the Sxxx, xxx should be the physical station number, i.e., the port number of the station. So, even if the station number was changed from 102 to 702, the physical station number is not changed:

```
mon>t ceh s002
```

Monitor - Dump Memory

This command dumps memory between the two addresses (which are in hexadecimal format).

IMPORTANT: If you omit one of the two address ranges, memory is dumped from the specified until Ctrl+C is pressed.

Monitor - Modify Memory

This command modifies memory from the from the specified until Ctrl+C is pressed.

Monitor - COL Status

This command is used to show the status of a CO line connected to the SBX IP system.

Conditions:

- This command can be executed when Remote Diagnostics is connected to the SBX IP system.
- If the OK button is clicked without entering a value in the Enter Command Argument dialog box, a message appears to indicate "Empty field is not allowed".
- You can cancel the command by clicking the X button on the top right side of the Enter Command Argument dialog box.
- The argument is limited to 6 characters.
- The argument uses a physical port number that starts from 1.
- If a non-numeric value is entered, the SBX IP system uses the first port number.
- If an invalid value (or value that is too large) is entered, the SBX IP system handles the error.

Procedure

Select the CO Status sub-menu in Commands menu, or click CO Status Command Bar button.

-or-

In the Command Edit Box, enter "c #" (# : Port Number), then click the Enter button.

-or-

In Remote Command Combo Box, select CO Status, then click the Execute button.

For example, to show the status of CO number 07:

```
mon> c 07
```

The following is an example of CO line status:

```
Slot0, Chan0, State0, AscD255T255
```

```
Slot = 00, Dev No = 00, highway = 00, Timeslot = 2341cc
```

```
RX_Sum Loc = ffff, TX_Sum Loc ffff
```

```
Ucd0, Store0, Sent0
```

```
22739c 00 00 00 ff 00 00 00 ff ff ff 05 ff ff ff 01 00  
2273ac 00 ff ff ff ff 00 ff 00 00 00 00 00 00 00 00  
2273bc 00 00 00 00 00 00 00 00 00 00 00 00 00 00 00  
2273cc 00 00 00 00 00 00 00 00 00 00 00 00 00 00 00  
2273dc 00 00 00 00 00 00 00 00 00 00 00 00 00 00 00  
2273ec 80 00 00 10 ff ff 00 00 00 00 00 00 00 00 00  
2273fc 00 00 00 00 00 00 00 00 00 00 00 00 00 00 00  
22740c 00 00 00 00 00 00 00 00 00 00 00 00 00 00 00  
22741c 00 00 00 00 07 00 00 00 00 00 00 00 00 00 00  
22742c 00 00 ff 00 00 ff 00 ff 00 ff 64 ff 00 00 00 ff  
22743c ff 00 00 00 00 ff ff 00 00 00 00 00 00 00 00  
22744c 00 00 00 00 00 00 ff ff ff 00 ff 00 ff ff 00 ff  
22745c 00 00 00 ff ff 00 ff ff ff ff 00 00 00
```

Monitor - STA Status

This command is used to show the status of a station connected to the SBX IP system.

Conditions:

- This command can be executed when Remote Diagnostics is connected to the SBX IP system.
- If the OK button is clicked without entering a value in the Enter Command Argument dialog box, a message appears to indicate "Empty field is not allowed".
- You can cancel the command by clicking the X button on the top right side of the Enter Command Argument dialog box.
- The argument is limited to 6 characters.
- The argument uses a physical port number that starts from 0.
- If a non-numeric value is entered, the SBX IP system uses the first port number.
- If an invalid value (or value that is too large) is entered, the SBX IP system handles the error.

Procedure:

Select the Station Status sub-menu in the Commands menu, or click the Station Status Command Bar button.

-or-

In the Command Edit Box, enter "s #" (# : Port Number) , then click Enter.

-or-

In the Remote Command Combo Box, select Station Status, then click Execute button.

For example, to show the status of station 107:

```
mon> s 008
```

The following is an example of STA status:

```
Slot1, Chan97, State1, AscD255T255
Ucd0, Store0, Sent0
Xfer0, Hold0, Held255

22175c 00 01 01 04 00 61 01 ff ff ff ff ff ff 00 ff ff
22176c ff ff ff 40 00 00 80 00 60 18 00 00 00 ff ff 00
22177c 00 00 00 00 00 ff ff ff ff 00 0a 08 00 ff 00 00
22178c ff ff 00 00 ff 00 00 00 00 00 00 00 ff ff ff ff
22179c ff ff ff 00 ff 00 00 00 00 00 00 00 00 00 00 00
2217ac 00 00 00 00 00 00 00 00 00 00 00 00 00 00 00
2217bc 00 00 00 00 00 00 00 00 00 00 00 00 00 00 00
2217cc 00 00 00 00 00 00 00 ff ff ff ff ff ff ff ff
2217dc ff ff ff ff ff ff ff ff ff ff ff ff ff ff ff
2217ec ff ff ff ff ff ff ff ff ff ff ff ff ff ff ff
2217fc ff ff ff ff ff ff ff ff ff ff ff ff ff ff ff
22180c ff ff ff ff ff ff ff ff ff ff ff ff ff ff ff
22181c ff ff ff ff ff ff ff ff ff ff ff ff ff ff ff
22182c ff ff ff ff ff ff ff ff ff ff 00 00 13 39 2e
22183c 00 2a 05 00 ff 00 00 00 00 00 00 14 00 01 00 00
22184c 00 00 00 00 00 00 00 00 00 01 00 00 00 00 00
22185c 00 00 00 ff 00 18 00 00 00 00 ff ff ff ff 01 b8
22186c 00 00 ff ff 00 00 00 00 00 22 18 74 00 22 18 74
22187c 00 22 18 7c 00 22 18 7c 00 00 00 00 ff 00 ff ff
22188c 00 00 00 ff 84 ff ff ff ff 02 84 ff ff ff ff 02
22189c ff ff 00 00 00 ff ff 00
```

Monitor - Print Channel Assign

This command sets the print port. You can select one of several print ports. By default, serial interface unit 1 is used.

Monitor - x

This command is used to log out from the SBX IP system.

Conditions:

- This command can be executed when Remote Diagnostics is connected to the SBX IP system.

Procedure:

Select the Log Out sub-menu from the Commands menu, or click the Log Out Command Bar button.

-or-

In the SBX IP Command Edit Box, input "x", then click Enter

-or-

In the Remote Command Combo Box, select Log Out, then click Execute.

Monitor - ?

This command is used to show the Help messages of Remote Commands.

Conditions:

This command can be executed when Remote Diagnostics is connected to the SBX IP system.

Procedure:

Select the Help Message sub-menu from the Commands menu, or click the Help Message Command Bar button.

-or-

In the SBX IP Command Edit Box, input "?", then click Enter

-or-

In the Remote Command Combo Box, select Help Message, then click Execute.

Maintenance - Display Board Configuration Table (bc)

This command is used to show the board configuration for the SBX IP system.

Conditions:

This command can be executed when Remote Diagnostics is connected to the SBX IP system.

Procedure:

Select the Board Configuration sub-menu from the Commands menu, or click the Board Configuration Command Bar button.

-or-

In the SBX IP Command Edit Box, input "bc", then click Enter

-or-

In the Remote Command Combo Box, select Board Configuration, then click Execute.

Maintenance - B-channel Listening(bl)

This command is used to show B-channel Listening of a specified time slot.

Maintenance - View Board Status(bs ##)

This command shows board status, where ## is the slot number.

Maintenance - Display HDLC Status(hd)

This command shows HDLC status.

Maintenance - Log View or Clear(log view | clear)

This command can be used to view and clear Log information.

Maintenance - Remote System Reset (reboot)

This command resets the system, and requires that the admin password be entered twice.

NOTE: If an admin password does not exist, 147* can be used temporarily as the admin password.

Maintenance - Traffic Analysis**(ta allperiodperiod_abortatdcallsum callhour hw cosum cohour)**

This command provides information regarding analysis data.

Command options are:

- ta all<timetype>- Print All Traffic Report
- ta period<hhmm> <timetype>- Print Traffic Report Periodically
- ta period_abort- Cancel Periodic Print
- ta atd<timetype>- Print Attendant Traffic Report
- ta callsum- Print Call Summary Report
- ta callhour- Print Call Hourly Report
- ta hw <timetype>- Print H/W Usage Summary Report
- ta cosum <timetype>- Print CO Traffic Summary Report
- ta cohour<cogrp#>- Print CO Traffic Hourly Report

timetype- tt|yt|lh|yp|tp

- tt : Today Total
- yt : Yesterday Total
- lh : Last Hour
- yp : Yesterday Peak
- tp : Today Peak

Maintenance - Display Time-slot Assignment(s)

This command displays time-slot assignment.

Maintenance - Software Upgrade(up)

This command upgrades software.

Maintenance - WTIB Statistics(ws ## command)

This command shows the WTIB statistical data.

Command options are:

?: Help

upload: Upload Data statistics data

call: Total number of call & direction of the call

subs: Information per subscribed device

eoc: End of call

cell: Usage of frequency and slot

traf: Show holding time

acce: Access info.(basic/hand-over)

clea: Clear statistics data

Maintenance - Exit(x)

This command is used to log out of the SBX IP system.

Conditions:

- This command can be executed when Remote Diagnostics is connected to the SBX IP system.

Procedure:

Select the Log Out sub-menu from the Commands menu, or click the Log Out Command Bar button.

-or-

In the LDK Command Edit Box, enter "x", then click Enter.

-or-

In the Remote Command Combo Boxes, select Log Out, then click Execute.

Maintenance - Help(?)

This command is used to show the Help messages of Remote Commands.

Conditions:

- This command can be executed when Remote Diagnostics is connected to the SBX IP system.

Procedure:

Select the Help Message sub-menu from the Commands menu, or click the Help Message Command Bar button.

-or-

In the SBX IP Command Edit Box, input "?", then click Enter

-or-

In the Remote Command Combo Box, select Help Message, then click Execute.

Diagnostic - Configuration Constraint(db cc)

This command shows whether or not the current configuration meets the configuration constraints.

Diagnostic - Preprogrammed Fault(db pf)

This command shows preprogrammed faults. It verifies whether or not the admin programmed data is different from the boards that are installed in the system. In addition, it prints a warning message when differences are detected.

Diagnostic - Time-slot Conflict(db ts slcf)

This command provides information regarding the time-slot assignment table and time-slot assignment conflict status. In the case of PRIB, channel 31, 32 should be assigned to the same time slot of channel 1.

Command options are:

sl - time-slot assignment table

cf - time-slot conflict

Diagnostic - highway Test(db ht ## ## #)

This command tests PCM highways using one DKT and one DTMF receiver. If a slot number, dtmf receiver duration time, and highway number have been assigned, Remote Diagnostics tests 48 time-slots in the specified highway.

NOTE: The first DKT of the assigned slot is used for the test. The DKT is connected to time-slots successively, and DTMF tone is also connected to that time-slot. If the DKT receives the specified DTMF tone, the time-slot is considered to be operating correctly.

The command is as follows:

db ht xx yy # (xx: slot number (DTIB), yy: dtmf duration time, #: highway number(0-7))

Diagnostic - DTRU Test(db dt)

This command tests the DTMF receiver. This feature tests all DTMF receivers in the system. Currently, a maximum of 32 dtmf receivers can be tested

Diagnostic - CPTU Test(db ct)

This command tests the CPTU.

Diagnostic - Memory Test(db mt)

This command tests the DRAM modules. It writes specified value (e.g. 0x5a) to the DRAM, then reads again to make sure valid data is being read.

Diagnostic - RTC Test(db rt)

This command tests the RTC. It shows the current time, then allows you to modify it. The time does not elapse when you test RTC, therefore, the time must be corrected before the process is complete.

Diagnostic - Power Capacity(db pc)

This command provides information regarding the power capacity of the PSU, as well as current power usage status of the system. If the total power usage per rack exceeds the limit, the configuration must be changed.

Diagnostic - RGU Capacity(db rc)

This command provides information regarding RGU capacity. This feature shows RGU capacity, CO incoming ring cadence, and ICM call ring cadence.

NOTE: It is not necessary to uninstall the station even if the number of stations exceeds the RGU capacity.

Diagnostic - HDLC Status(de hs)

This command shows HDLC status.

Diagnostic - Reset Information(dr ri)

This command shows Reset Information.

Diagnostic - Resource Assignment(dr li d | c | v | a)

This command provides information regarding current resource assignment

d - DTMF receiver assignment

c - CPTU assignment

v - VMIB channel assignment

a - DTMF, CPTU, VMIB channel assignment

View Menu

The View menu is used for showing / hiding the Toolbar, Status Bar, Command Bar, Input Box Bar, and for Clearing the display area to start a new document.

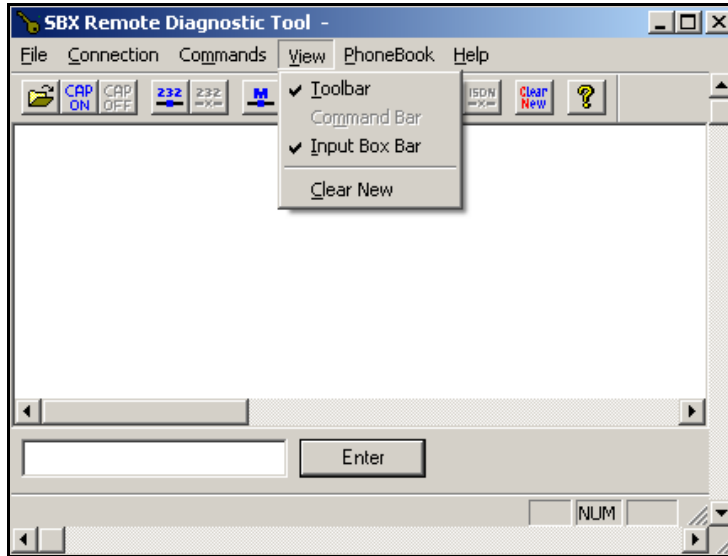

Toolbar Sub-menu

The Toolbar sub-menu is used to hide/show the Toolbar. A check mark appears next to this option when the Toolbar is displayed.

Procedure:

From the View menu, select the Toolbar sub-menu.

If the Toolbar is shown on the screen, it becomes hidden; if it isn't on the screen, it appears.

Command Bar Sub-menu

The Command Bar sub-menu is used to hide/show the Command Bar. A check mark appears next to this option when the Command Bar is displayed.

IMPORTANT: The Command Bar is available only when in Monitor or Maintenance Mode.

Procedure:

From the View menu, select the Command Bar sub-menu.

If the Command Bar is shown on the screen, it becomes hidden; if it isn't on the screen, it appears.

Input Box Bar Sub-menu

The Input Box Bar sub-menu is used to hide/show the Input Box Bar. A check mark appears next to this option when the Input Box Bar is displayed.

Procedure:

From the View menu, select the Input Box Bar sub-menu.

If the Input Box Bar is shown on the screen, it becomes hidden; if it isn't on the screen, it appears.

Clear New Sub-Menu

The Clear New sub-menu is used for clearing the Data Display Area and starting a new document.

NOTE: Because a new document has no name until it is created and saved, "Untitled" appears as the name of the document in the title bar.

Procedure:

From the View menu, select Clear New sub-menu.

-or-

Use the icon  in the toolbar.

All the data displayed in Data Display Area is erased, and a new document is started.

Help Menu

The Help menu contains the About SBX Remote Diagnostic Tool sub-menu.

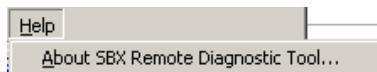

NOTE: Online help is not supported in this version of SBX IP.

About SBX Remote Diagnostic Tool Sub-menu

When the About SBX Remote Diagnostic Tool sub-menu is clicked, the About SBX Remote Diagnostic Tool dialog displays, and “Remote Diagnostics Tool”, the software version, and copyright information is displayed.



Procedure:

1. Select the About SBX Remote Diagnostic Tool sub-menu in the Help menu.
-or-
Use the icon  in the toolbar.
The About SBX Remote Diagnostic Tool dialog displays.
2. Click OK to close the dialog window.

Data Display Area

The Data Display Area option displays the data from serial port, modem, or data file. When displaying data, this area follows certain rules and executes functions according to those rules.

Data Display Functions

- When data comes from the serial port or modem, the Data Display Area automatically scrolls to the last line if the data exceeds the size of the Data Display Area.
- If the data comes from the data file, the Data Display Area displays the data from the first line.
- If a data file is opened while data is coming from the serial port or modem, and being displayed in the Data Display Area, any previously displayed data is erased, and new data replaces it. If additional data continues to come from the serial port or modem, the data is appended from the last line of the currently displayed file data; the file name remains the same. This process prevents loss of real time data from the serial port or modem.
- If you execute an SBX command after opening a new document, the document is automatically closed, and a new one is displayed (with the name "Untitled").
- Once a file name is assigned for the data in the Data Display (that is by using the Save sub-menu or the Save As sub-menu), the file name remains the same even if more data comes from the serial port or modem. Therefore, the appended data included and stored in the same file.
- If the Clear New sub-menu is selected or the Clear New tool button is clicked, when a document appears in the Data Display Area, the document is automatically closed, and a new one is displayed (with the name "Untitled").

NOTE: If the data to be displayed exceeds the size of the Data Display Area, a vertical scroll bar appears to enable scrolling in the Data Display Area. A horizontal scroll bar is always provided even when the width of the displayed data does not exceed the size of the Data Display Area.

Automatic Data Storing Functions

Generally; the number of lines of data displayed in the Data Display Area exceeds 2,000 lines, Remote Diagnostics automatically saves the displayed data into a data file, and clears the Data Display Area. At that point, any data still coming in is displayed. And the process repeats again until the all of the data is complete.

- The maximum number of lines of data is system-dependant. If the PC is using smaller fonts, more lines will be displayed.
- The name of the file that is saved when 2,000 lines of data is exceeded (as described above), has the format of "Thhmmss.dat" (hh : current hour, mm: current minute, as: current second). The file is saved in the same directory as the one where Remote Diagnostics is installed. You can open this file by using the Open sub-menu or the Open tool button.
- It is possible for data to be lost during the automatic data storing function. This happens especially when the data transfer rate is high while the performance of the PC is low, or the PC is performing other background tasks (such as printing). It may be that the first line of data displayed after automatic data storing may have a broken format.

IMPORTANT: If the performance of the PC is not optimal, some scrolled data may not have complete formatting. If this happens, refresh the area by using the scroll bar to scroll in the Data Display Area.

VoIB Maintenance

1. Connect the serial port of the VoIB at a rate of 38400 bps, then enter the Maintenance window.
2. To enter Trace Mode, type the password "jannie", then press Enter.

```
=====
                        MAINTENANCE MENU
=====
nc                        Display Network Configuration
nr                        Display Network Resources
ns |hi|hm|hg|            Change Network Resources
                        - hi(host ip), hm(subnet mask), hg(gateway ip)
bc                        Display Board Configuration
cu                        Display Channel Usage
dir c                    Display files
del c <filename>        Delete a file
ren                      Rename a file
format                  Format disk
chkdsk                  Scan disk
fio                      Disk io control
link                    Display ethernet link
linkset speed-select(10/100) duplex-mode(half/full)
linkauto                Force ethernet link to AutoNego mode
dsp                     DSP Status Check
stack                  Display Stack Status
reset |view|clear|system| System reset related
t |s|r| |mppp|voip|RSGM|DSP| Set/Reset trace data
t v                    View trace ON/OFF mode
s                      View Task Status

?      Help
x      Log off
```

Example of enabling Trace

Type root:\t>, then press Enter.

```
maint> t u
Trace Settings
MPPP CMD/EVT : OFF
VOIP Stack Log : OFF
DSP          : OFF
HTTP        : OFF
RSGM       : OFF

maint> t s voip

maint> t u
Trace Settings
MPPP CMD/EVT : OFF
VOIP Stack Log : ON
DSP          : OFF
HTTP        : OFF
RSGM       : OFF

maint> t r voip

maint> t u
Trace Settings
MPPP CMD/EVT : OFF
VOIP Stack Log : OFF
DSP          : OFF
HTTP        : OFF
RSGM       : OFF

maint>
```

Troubleshooting

Symptoms and Solutions

| PROBLEM | CAUSE/SYMPTOM | SOLUTION |
|--------------------------------|---|---|
| SYSTEM POWER FAILURE | Power short circuit in some board(s) | <ul style="list-style-type: none"> • Exchange the malfunctioning board for one in good working condition. • Dust each board with a dry cloth. • Check the PSU fuse. • Replace the PSU with an identical one. |
| | LD1-4 LEDs on the MBU are All ON or All OFF | |
| SYSTEM DOES NOT OPERATE | Power short circuit in some board(s) | <ul style="list-style-type: none"> • Check the connection of each board with the MBU. • Check the PSU. • Check for a short circuit on the MBU or other boards. • Press the Reset button when the DIP switch (SW1 for database protection) is in the default position. |
| | Bad board connection | |
| | System database not working | |
| DKTU DOES NOT OPERATE | Bad extension circuit | <ul style="list-style-type: none"> • Exchange the malfunctioning board for one in good working condition. |
| | Bad connection between the MBU/EMBU/3x8 Expansion & DKT | <ul style="list-style-type: none"> • Check the connection between the SLT line and DKT on MDF, then fix any mismatches. • Repair a broken connection between the system and DKT. |
| | Proximity of DKT and system | <ul style="list-style-type: none"> • Check the distance between the MBU/EMBU/3x8 Expansion and the DKT. |
| | Bad DKT | <ul style="list-style-type: none"> • Plug the DKT into another extension port that has been verified as working. • If the DKT still does not work properly, replace the DKT. |

| PROBLEM | CAUSE/SYMPTOM | SOLUTION |
|--|--|---|
| SLT DOES NOT OPERATE | Bad MBU/EMBU/3x8 Expansion board | <ul style="list-style-type: none"> • Exchange the board for one in good working condition. |
| | Bad connection between the MBU/EMBU/3x8 Expansion & SLT | <ul style="list-style-type: none"> • Check that the board connection between the lines of the SLT and DKT on the MDF, then fix any mismatches. |
| CO LINE OPERATION FAILURE | ANCR fail | <ul style="list-style-type: none"> • Check the U8 (Voice processing and Tone detection device). |
| | Bad connection | <ul style="list-style-type: none"> • Check all connections. |
| EXPANSION KSU DOES NOT OPERATE | Power ON sequence | <ul style="list-style-type: none"> • After turning on the Expansion KSU, turn on the Basic KSU. Then press the Reset button. |
| | Link cable connection | <ul style="list-style-type: none"> • Check the link cable to verify the connection and its working condition. |
| NOISE ON EXTERNAL MOH AND PAGING PORT | Induced noise on the wire between the system and the amplifier | <ul style="list-style-type: none"> • Make sure a shielded cable is in use as the connection wire between the system and the amplifier. |
| | Excessive input level from the external music source | <ul style="list-style-type: none"> • Decrease the output level of the external music source by using the volume control on the music source. |

System Setup Quick Reference

Quick Start

To initialize the system database:

- With system power OFF, set the Red/White color SW2 [BATT] to the ON position.
- Ensure switch 4 on SW1 is in the ON position. SW 1 is a bank of 4 switches.
- Power the system up; wait ten seconds. Press SW3 to reset the system, then wait 10 seconds.
- Place switch 4 on SW 1 to the OFF position.

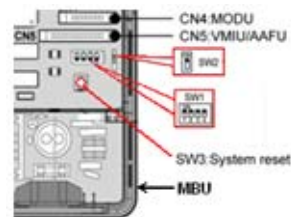

To set the KSU admin password:

1. Access system programming by pressing TRANS/PGM, *, #.
2. Press PGM and dial 162.
3. Enter a 4-digit numeric password and press SAVE.

To set the KSU LAN port IP address:

1. Access system programming by pressing TRANS/PGM, *, #.
2. Press PGM and dial 108.
3. Press Flex Button 2.
4. Enter the IP address WITHOUT a decimal or *, then SAVE (for example, enter 172016002015 to represent the address 172.16.2.15)
5. Press Flex Button 4.
6. Enter the default gateway address, then SAVE.
7. Press Flex Button 4, then SAVE.
8. Reset the system in order for the changes to take effect.

Default passwords

- KSU
Admin from Keyset - BLANK
Admin from PCAdmin - BLANK
RS-232 board trace - jennie
RS-232 maintenance - brandy
- PCAdmin program (not KSU)
Default user name - administrator
Password - 0000

RS-232 port settings

Baud rate - 19200
Parity - none
Stop bits - 1
Flow control - none

Default IP address

KSU - 192.168.1.1
VoIB - (VoIP card) - 0.0.0.0

NOTE: Refer to the *SBX IP Programming & Operations Guide* for detailed programming information.

Index

Numbers

- 3x16 Expansion Board
 - 3 CO Line and 16 Digital, 4-13
- 3x8 Expansion
 - Modular Jack (MJ1-MJ2) Pin Assignment, 4-13
- 3x8 Expansion Board
 - 3 CO Line and 8 Hybrid, 4-12

A

- Additional Terminal Connections, 5-7
- Alarm Detection Wiring, 5-8

B

- Basic
 - Programming, 6-2
 - Terminal Connection, 5-4
- Before Starting the SBX IP, 6-1
- BKSU/EKSU
 - Cable Wiring, 5-9
 - Rack Mount Wiring, 5-10
 - Wall Mount Wiring, 5-9
- BLF
 - File menu, 6-18
 - Manager Installation, 6-16
 - Manager screen, 6-17
 - Network traffic window, 6-18
 - Station list window (Extension status), 6-18
 - System list window (Status of systems), 6-17
- Board
 - Assignment (PGM 101), 6-8
 - Installation, 4-1
- Button Explanation (IP7224), 6-3

C

- Cautions, 1-2
- CO Line & Extension Board Installation, 4-12
- Connecting
 - Additional Terminals, 5-7
 - Expansion KSU to Basic KSU, 3-13

D

- Desktop Mounting, 3-11
- Disposal of Old Appliances, 1-3
- DKT Programming, 6-2
- DTIB-16, 4-14

E

- EKSU
 - Wall Mounting, 3-15
- EMBU
 - CN13 Pin Assignment (Relay Contact), 4-11
 - Connection Ports, 4-9
 - Connector/Modular Jack/Switch Functions, 4-9
 - LED Indications, 4-9
 - MJ1(CO), 4-10
 - Modular Jack (MJ1 - MJ3) Pin Assignment, 4-10
- Expansion KSU
 - Installation, 3-12
 - Mounting, 3-15
- Expansion Main Board Unit (EMBU), 4-8
- External
 - Backup Battery Installation, 3-8
 - Music Source Wiring, 5-8

- F**
- Flexible Numbering Plan
 - (PGM 105), 6-11
 - (PGM 106-107, & 109), 6-12
 - Frame Ground Connection, 3-7
- G**
- Grounding the KSU, 3-7
- I**
- Installation
 - CO Line & Extension Boards, 4-12
 - Precautions, 3-2
 - Introduction, 1-1
 - IP7224 Button Explanation, 6-3
 - IP Phones on the SBX IP, 5-11
- K**
- KSU
 - Exterior and Dimension, 3-4
 - Installation, 3-1, 3-3
 - Mounting, 3-9
- L**
- Loading a 2.5 Database into a 3.0 System, 7-8
 - Logical Slot Assignment (PGM 103), 6-9
- M**
- Main Board Unit
 - MBU (p/n 4000-00), 4-2
 - MBU (p/n 4000-03), 4-2
 - MBU
 - Alarm Detection Wiring, 5-8
 - CN13 Pin Assignment (Relay Contact), 4-5
 - Connection Ports, 4-3
 - MJ1 (CO), 4-4
 - MJ2 (Extension), 4-4
 - Switch, LED, and Connector, 4-6
 - MBU/EMBU Relay Contacts, 5-8
 - Modem Function Unit (MODU), 4-15
 - Modular Jack (MJ1 - MJ3) Pin Assignment, 4-4
- N**
- Nation Code and Site Name (PGM 100), 6-6
 - New VMIB prompts, 8-9
- P**
- Precautions, 1-2
 - Pre-Installation, 3-1
 - Pre-Programming, 6-6
 - PRI/T1 LED Indications, 4-17
 - Programming (Basic), 6-2
- R**
- Relay Contacts - MBU/EMBU, 5-8
 - Remote Diagnostics, 9-1
 - Commands Menu, 9-28
 - Connection Menu, 9-6
 - Data Display Area, 9-49
 - File Menu, 9-4
 - Full Screen Layout, 9-4
 - Hardware Configuration, 9-2
 - Hardware/Software Requirements, 9-1
 - Help Menu, 9-48
 - Important Notes for Users, 9-3
 - Uninstalling Software, 9-3
 - View Menu, 9-46
 - Resetting the System, 6-5
- S**
- Safety
 - Installation Instructions, 3-1
 - Requirements, 1-1
 - SBX IP System Highlights, 2-1
 - Specifications, 2-5
 - System
 - Connection Diagram, 2-2
 - IP Setup (PGM 108), 6-14
 - System Setup Quick Reference, A-1

T

- T1/PRI, 4-16
- T1/PRI Firmware Upgrade, 8-16
- T1/PRI LED Indications, 4-17
- Terminal Cabling Distance, 5-3
- Troubleshooting, 10-1

U

- Uploading new VMIB prompts, 8-9

V

- VMIB prompts
 - Uploading new prompts, 8-9
- VOIB
 - LED Indications, 4-19
 - Maintenance, 9-51
 - Pin assignment, 4-20
 - switch and connector functions, 4-19
 - S/W Upgrade by Web-based Connection, 8-13
 - Voice over Internet protocol Board (4ch), 4-18
- Voice Mail Interface Board (VMIB), 4-21
- VOIU -- Internet protocol unit (4ch), 4-20

W

- Wall Mounting, 3-9
- Wiring Precautions, 3-2

